

# SOCET GXP® and GXP InMotion™ Desktop v4.5.1.x cumulative release enhancements

Evan Miller  
GXP® Product Development



# SOCET GXP v4.5.1.x release enhancements



## SOCET GXP v4.5.1 release enhancements

- This presentation contains the enhancements included in SOCET GXP **v4.5.1.5**.
  - Released September 10<sup>th</sup>, 2024\*.
  - SOCET GXP v4.5.1.5 is patch 12 of the SOCET GXP v4.5.0.0.272 release build. Because all SOCET GXP patches are full installations, users have two options:
    - Upgrade an existing SOCET GXP installation by installing this patch, or...
    - For brand new installations, install this patch for a full installation that includes both the patch and the v4.5.0.0.272 base installation.

*\* Items in teal indicate new features included in the v4.5.1.5 update*

## Infrastructure updates

- New sensors, imagery, and other GEOINT data:
  - Mensuration Services Program (MSP) v2.1.1.
  - Geospatial Support Data Extensions Tagged Record Extension (GeoSDE TRE) support.
  - Pleiades 30-centimeter images.
  - COSMO-SkyMed second generation.
  - 3D Tiles 1.1.
  - SIX Library v3.1.14.
  - Added support for MSP v3.0.
  - Increased default performance preference to meet the needs of more performant hardware out of the box.
- Coordinate system support:
  - Added GEOID18.
  - Support for Web Mercator EPSG:3857 for Map streaming from sources such as Esri®.
  - Support CRS-1 (Open Geospatial Consortium Coordinate Reference System) for lossless image space streaming of raw image pixels.
  - Japan Plane Coordinate.
  - Added SIPS 2.5.2 support.
  - Increased GXP Job Service threads to meet the needs of more performant hardware out of the box.

## Infrastructure updates ...2

- Licensing:
  - New licenses are required with the release of SOCET GXP v4.5.0.x.
- Increase cache memory sizes for SOCET GXP and GXP InMotion to improve application performance.
- Third-party software updates:
  - GDAL v3.1.0.
  - LibTIFF v4.3.0.
  - HDF5 v1.12.
  - Java 8u322b06.
  - Microsoft® Visual Studio® 2019.
  - GeoPDF® SDK 7.3.5.16.
  - SIPS 2.5.2.

# Repository/Commuter licensing

- A new licensing option is available for Repository/Commuter licensing.
- Users can check out a license from the license manager, disconnect from the network, and continue using the desktop GXP® products.
- Introduces the GXP License Tool for clients.
  - Licenses can be checked out and returned via command line.
  - Administrators can use this function to control license access.

```

C:\Program Files\BAE SYSTEMS\SOCET GXP 4.5.0\bin>GxpLicenseTool.exe
GxpLicenseTool 4.5.0.6.166 Exportable
Log file is at C:\Users\          \AppData\Local\Temp\GxpLicenseTool.20221108122502.log
Application for management of local REPOSITORY/COMMUTER licenses modules.

Usage: GxpLicenseTool.exe ARGUMENTS
      [-log filename] -information
      [-log filename] -initialize
      [-log filename] -install LICENSE_GROUP -server SERVER_NAME
      [-log filename] -return LICENSE_GROUP

      -log FILE_NAME          - [OPTIONAL] Uses FILE_NAME as a
                             log file.

      -info | -information    - Print information about local
                             COMMUTER licenses.

      -init | -initialize     - Initialize License Data. Must be
                             run as an admin.

      -install LICENSE_GROUP - Check out LICENSE_GROUP to local
                             computer. This option can be given more the once.

      -return LICENSE_GROUP  - Return LICENSE_GROUP to server.
                             This option can be given more then once.

      -server SERVER_NAME    - Use SERVER_NAME for the license server.

Supported LICENSE_GROUP(s)
-----
ALL      - All local licenses. Only works with -return. This value is mutually
         exclusive to all other groups.
EXPIRED - Expired local licenses. Only works with -return. This value is
         mutually exclusive to all other groups.

2GP - Publisher for GeoPDF 2D Add-On      | 3GP - Publisher for GeoPDF 3D Add-On
BT  - Basic Targeting Bundle              | CARTO - Carto Bundle
CCD - Coherent Change Detection Add-On    | CDC  - CIB DPPDB-Like Creation Add-On
CS  - CoreSDK                            | FA   - Feature Automation Bundle
FE  - Feature Extraction Bundle           | FV   - Feature Validation Add-On
GA  - GeoAnalysis Bundle                 | GAT  - GeoAnalysis Targeting Bundle
GC  - GIS Connection Bundle              | GE   - GeoElement Bundle
GXC - GXP Xplorer Connector Add-On       | HEZ  - Hazard Estimation Zone Add-On
HWP - Hangul Word Processor Export Add-On | IDB  - InMotion Desktop Base Bundle
IDP - InMotion Desktop Plus Bundle       | NP   - NGA Pro Bundle
NPT - NGA Pro Targeting Bundle           | ORTHO - Ortho Bundle
PRO - Pro Bundle                         | REN  - Render Add-On
SEE - Spatially Enabled Exploitation Add-On | TA   - Terrain Automation Bundle
TE  - Terrain Edit Bundle                 | TRI  - Triangulation Bundle
UAV - Unmanned Aerial Vehicle Add-On     | VV   - VideoViewing Bundle
XA  - eXtreme Analysis Bundle            | XAT  - eXtreme Analysis Targeting Bundle

```

# New Synthetic Aperture Radar (SAR) capabilities

- Additional SAR functions added to the Analyze tab.
- View SAR using new values:
  - Beta Nought.
  - Sigma Nought.
  - Gamma Nought.
- Introducing several Speckle Noise Filters.

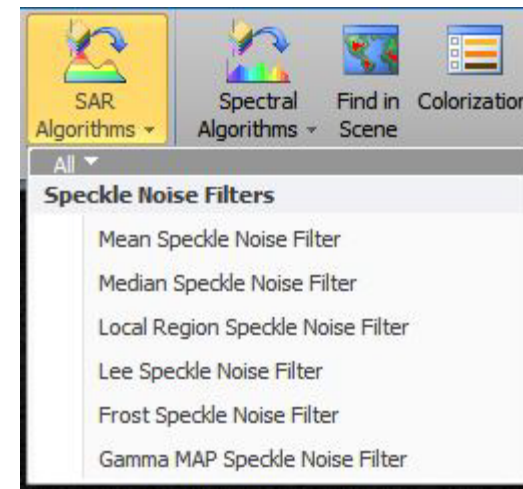
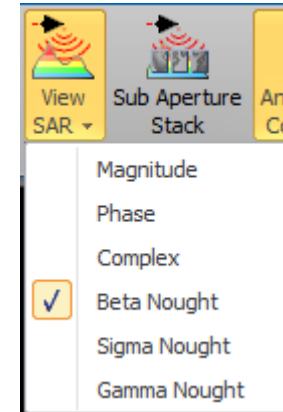

## Improved performance for opening Esri® file Geodatabase

- In previous versions of SO CET GXP, large file Geodatabases would take a long time to load.
- To reduce that load time a “More Esri® Rows” button was added, allowing the user to add more rows as needed.

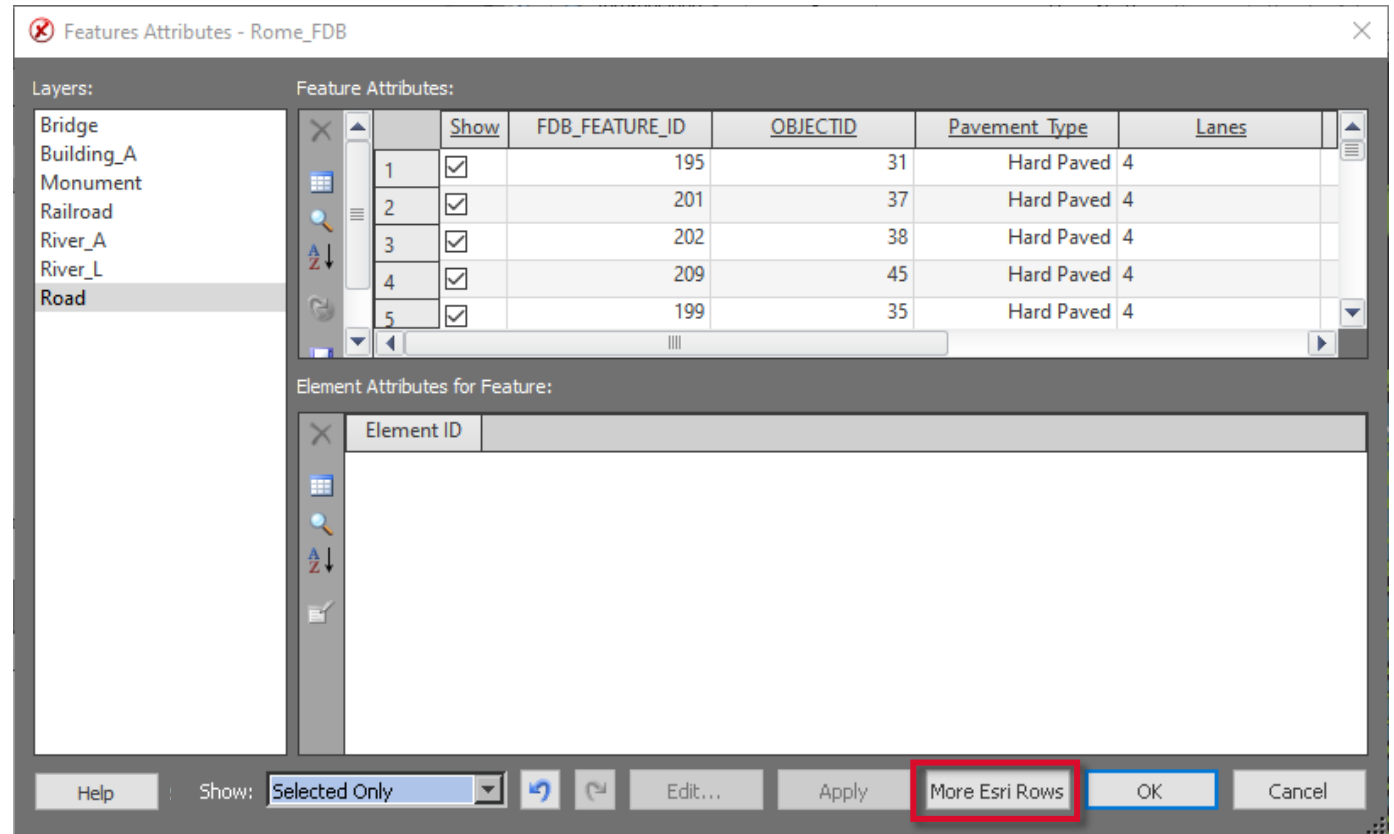



# Use a shapefile to define boundaries for geospatial tools

- Users can now define boundaries for all of the geospatial tools, this includes:
  - AutoSOCET.
  - Automatic Terrain Generation.
  - Triangulation.
  - Build Orthophoto.

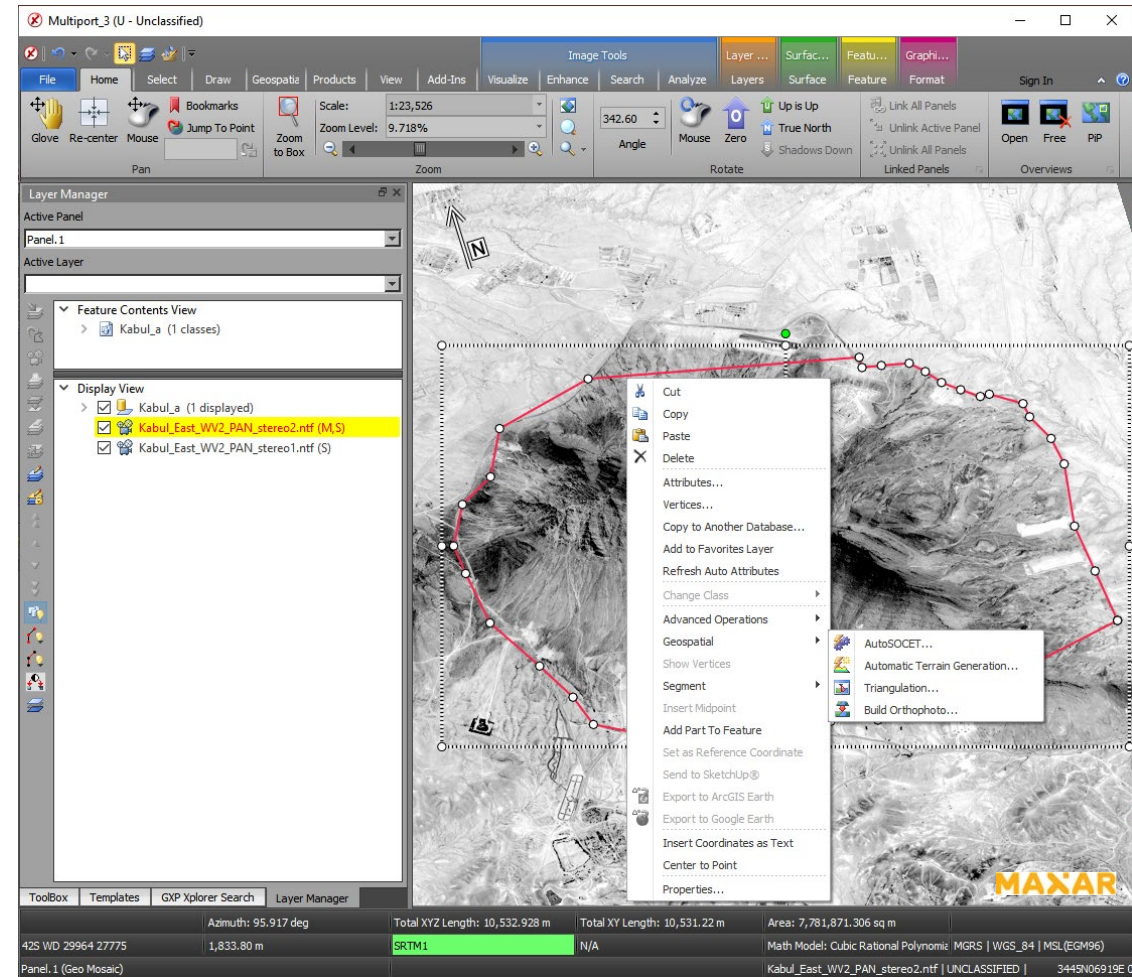

## Set spatial reference system when saving shapefiles

When saving out shapefiles, users can now set a different spatial reference system different from what is specified in the Workspace.

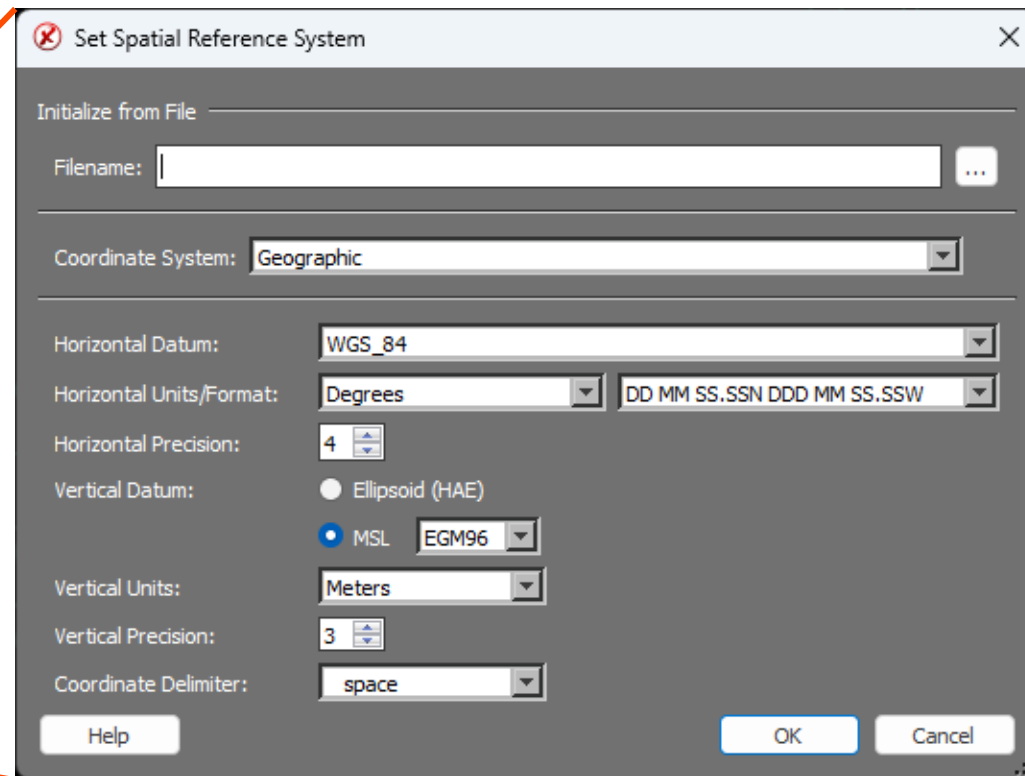
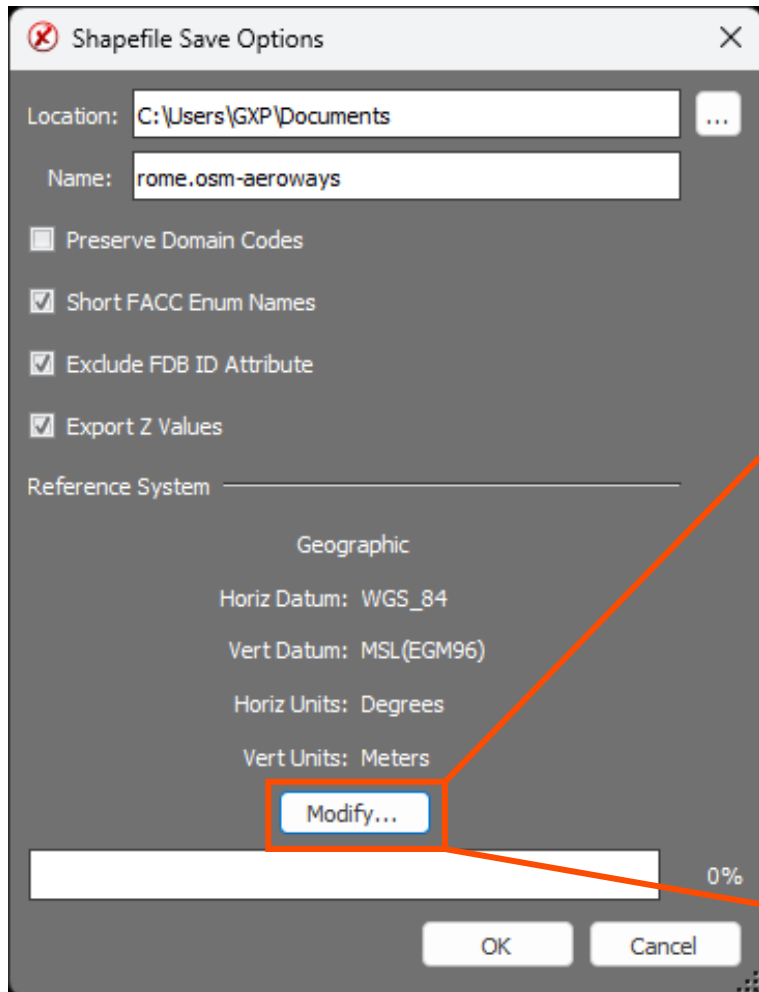

# Improved Help

New Help documentation template for improved navigation of the online users manual layout and style.

- SOCET GXP, GXP InMotion, and the License Manager have all been updated to the new User Manual format with focus on improvements to the layout and style.
- Improved font and management of content including the table of contents based on web page design practices.
- Expand all / collapse all within a help topic section.
- Highlight and print the document.
- Code Snippets – copy and paste command line arguments into a CMD prompt.

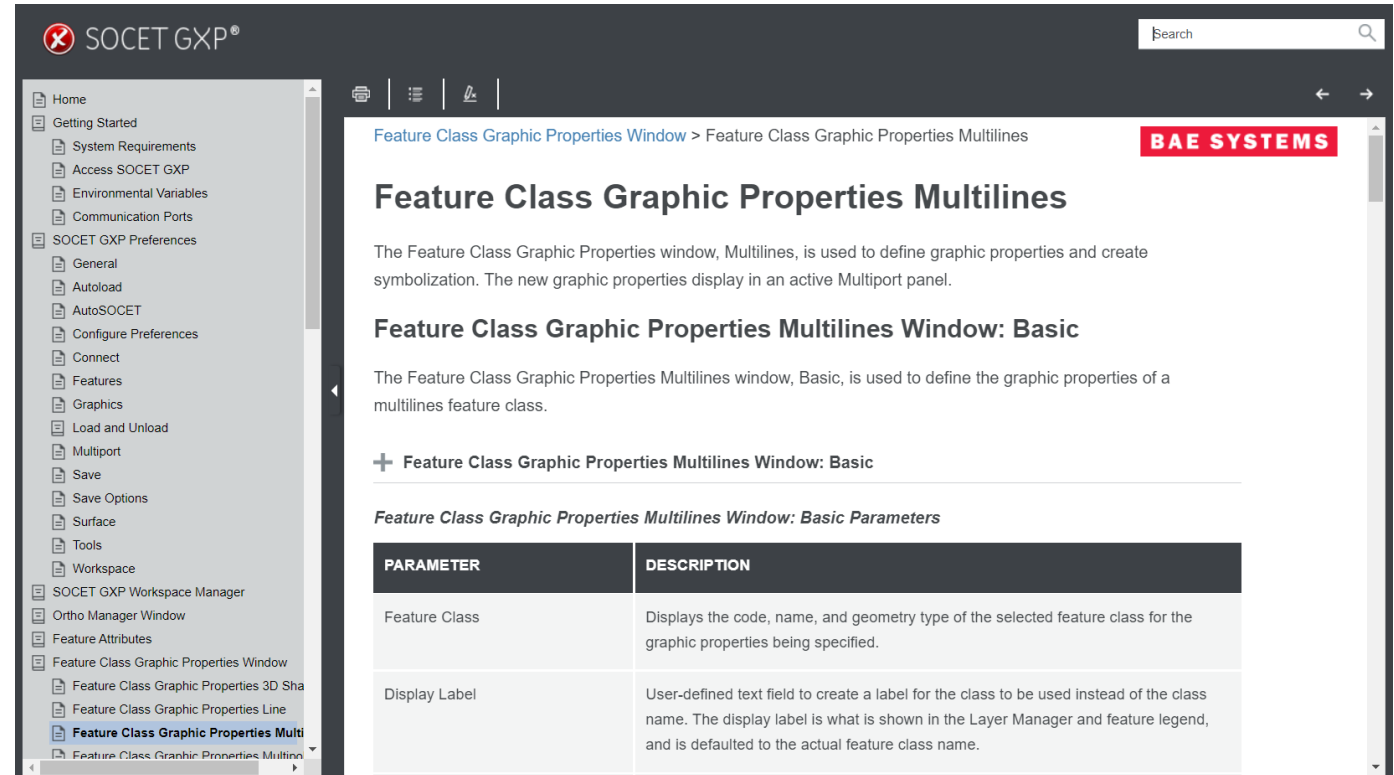

# Task Manager Image list

- Update the Task Manager user interface.
  - View long image names in the Task Manager Image list simple operations including resizing Image list and/or Task Manager window.

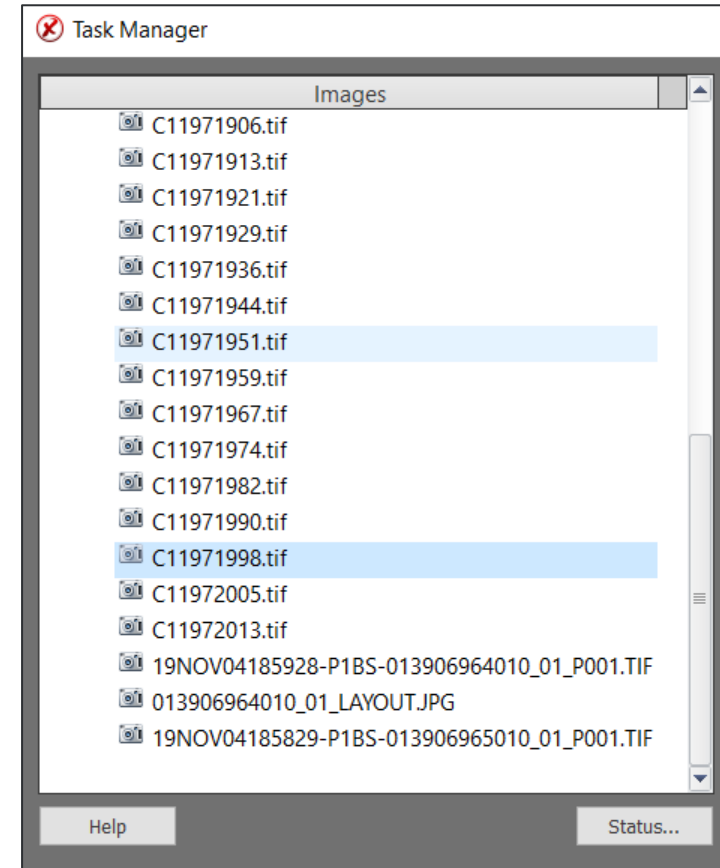
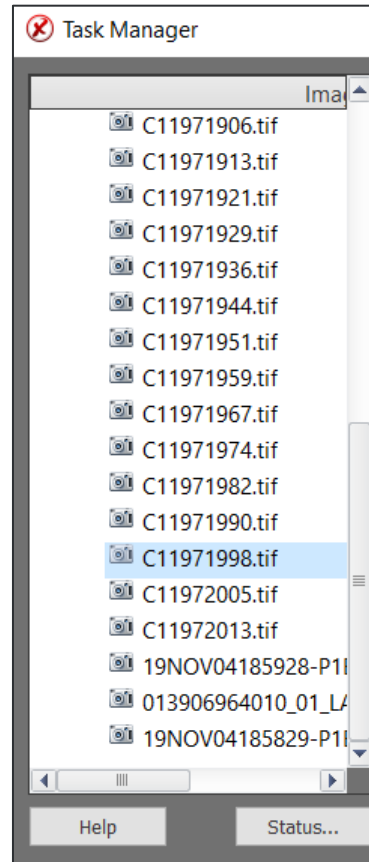

# Integration of SOCET GXP with Esri ArcGIS® Earth

- Interface with Esri ArcGIS® Earth using a simple button interface from the SOCET GXP Multiport™ add-ons tab.
  - Add image overlay layer ArcGIS Earth.
  - Add image footprint(s) layer ArcGIS Earth.
  - Add selected graphics layer ArcGIS Earth.
  - Add all visible scene layers ArcGIS Earth.

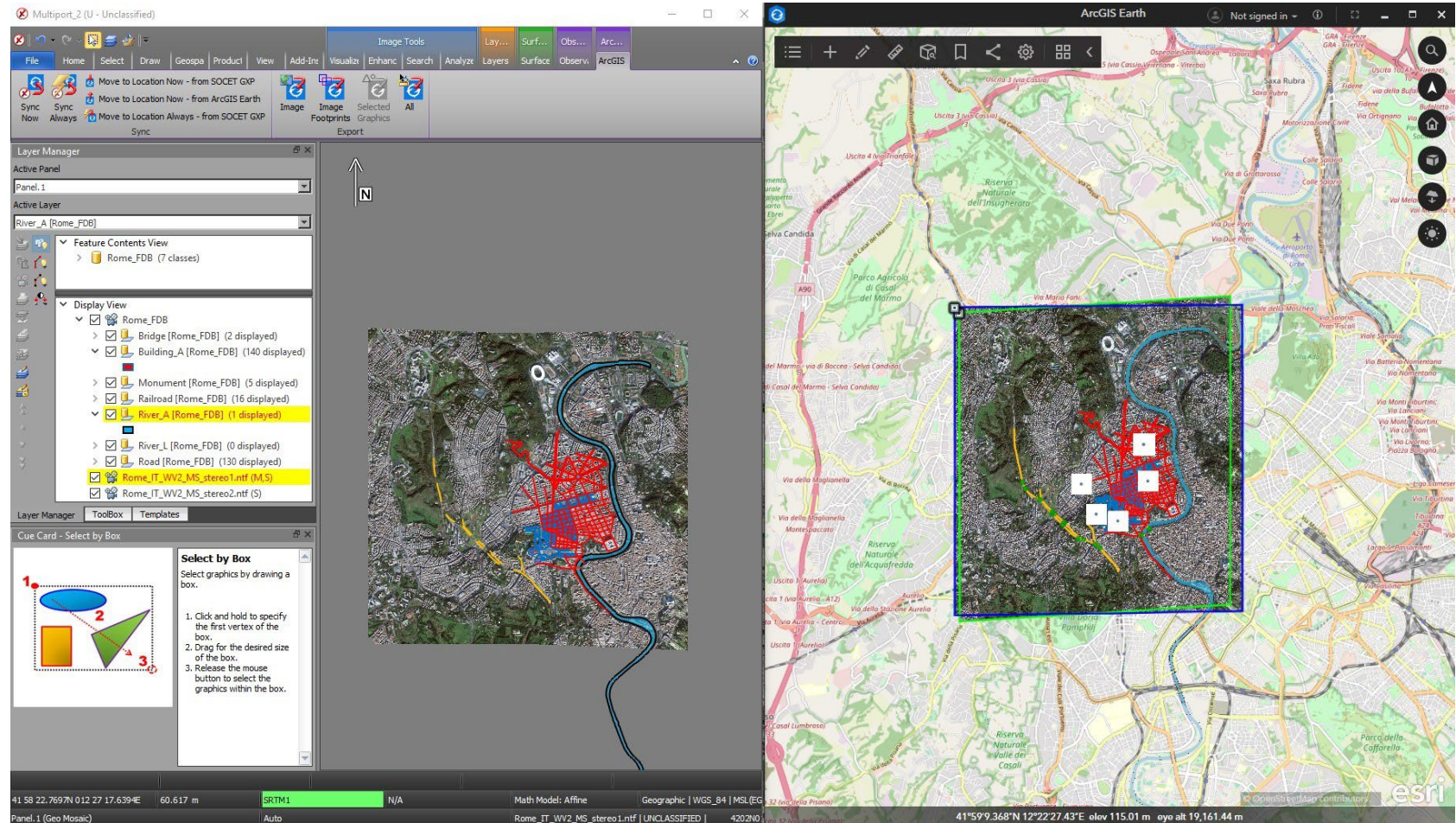

© 2024 Maxar Technologies.

# Integration of SOCET GXP with Esri ArcGIS Earth ...2

- Synchronize ArcGIS Earth with SOCET GXP.
  - Move SOCET GXP to ArcGIS Earth location.
  - Move ArcGIS Earth to SOCET GXP location.
  - Move ArcGIS Earth to SOCET GXP location always.

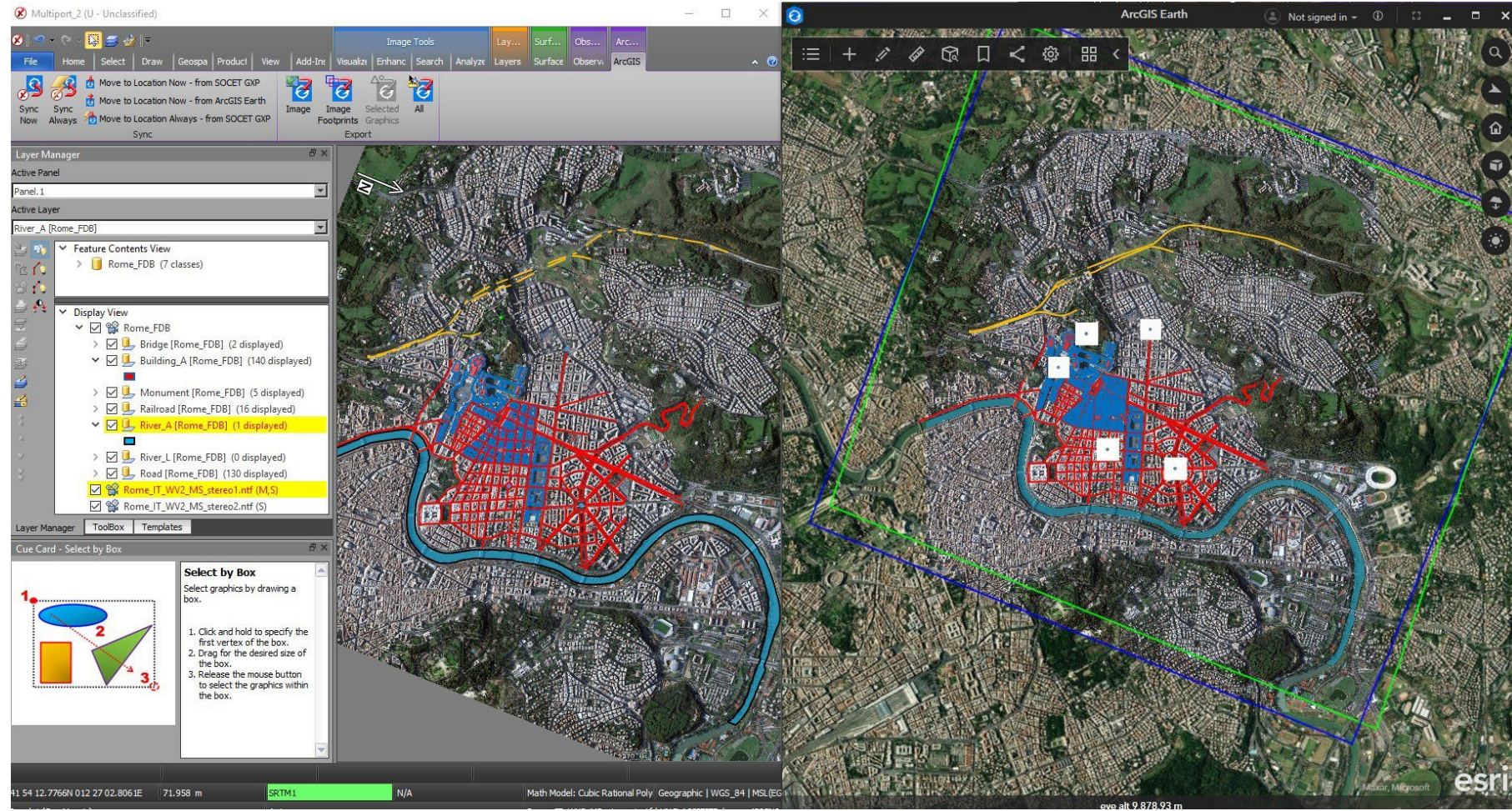

© 2024 Maxar Technologies.

## Integration of SOCET GXP with Esri ArcGIS Earth ...3

- Preference to automatically burn graphics into an image before synchronizing SOCET GXP with ArcGIS Earth.

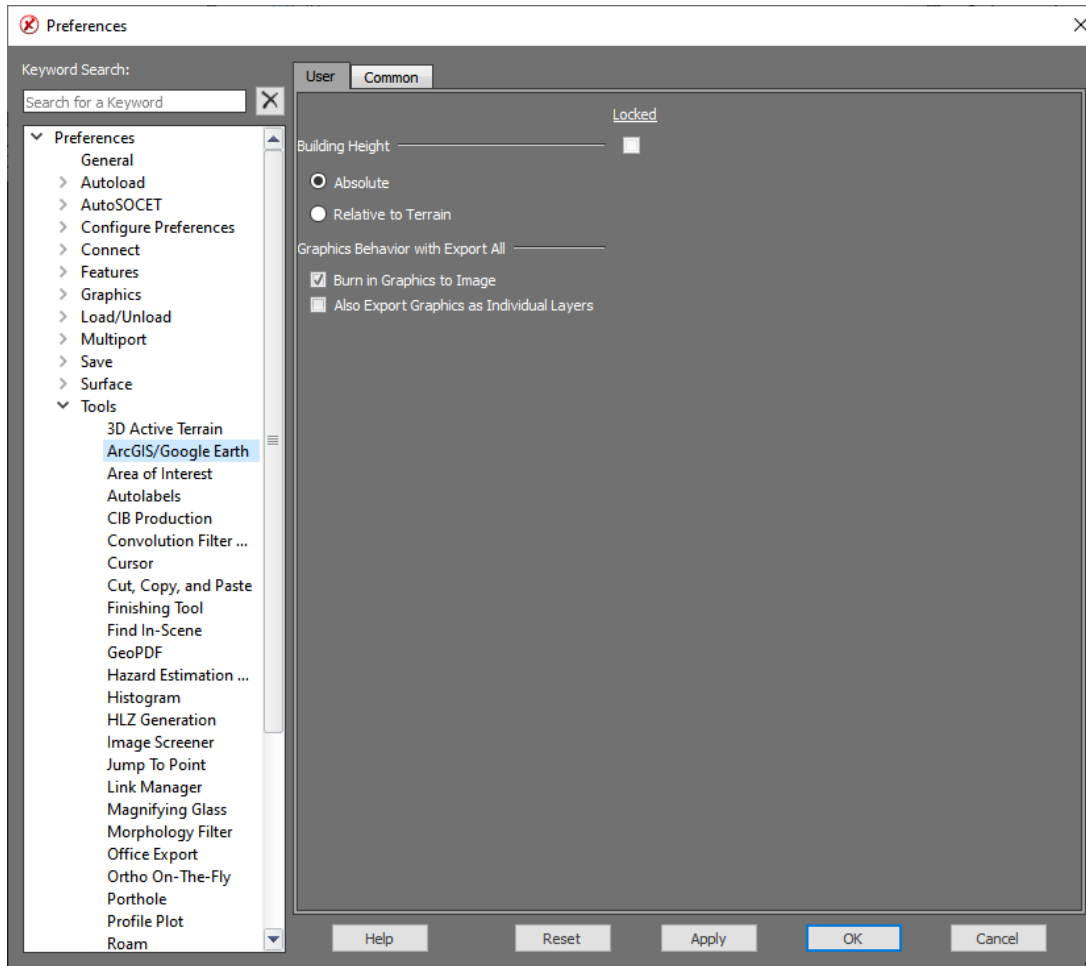

# New GXP Xplorer® Search functions

- Download a copy of the image from GXP Xplorer® to the local workstation.
  - New option in the right mouse menu.
  - Download Status in the GXP Xplorer Results panel.
- Image Thumbnail now available for preview.
- Filter rows by metadata values such as Size.

- Load into Workspace
- Download to Folder**
- Open New Multiport
- Open New Panel
- Replace in Search Panel
- Add To Search Panel
- Remove

© 2024 Maxar Technologies

| Date Collected           | Filename                   | Tags (Type)            | Size                                     | Image - Cloud Cover | Download Status |
|--------------------------|----------------------------|------------------------|--|---------------------|-----------------|
| No filter selected       | No filter selected         | No filter selected     |  | No filter selected  |                 |
| Jan 16, 2003, 7:27:18 PM | Stereo_Top_Right_po_104... | Image NITF NITF2.0 VIS | <input type="checkbox"/> 0 - 1 MB        | 0                   |                 |
| Jan 16, 2003, 7:27:18 PM | Stereo_Top_Left_po_1049... | Image NITF NITF2.0 VIS | <input type="checkbox"/> 1 - 50 MB       | 0                   |                 |
| Jan 16, 2003, 7:27:18 PM | Stereo_Bottom_Right_po...  | Image NITF NITF2.0 VIS | <input type="checkbox"/> 50 - 100 MB     | 0                   |                 |
| Jan 16, 2003, 7:27:18 PM | Stereo_Bottom_Left_po_1... | Image NITF NITF2.0 VIS | <input type="checkbox"/> 100 - 500 MB    | 0                   |                 |
| Jan 16, 2003, 7:27:18 PM | Stereo_Bottom_Left_po_1... | Image NITF NITF2.0 VIS | <input type="checkbox"/> 500 MB - 1 GB   | 0                   |                 |
| Jan 16, 2003, 7:27:18 PM | Stereo_Bottom_Left_po_1... | Image NITF NITF2.0 VIS | <input type="checkbox"/> Larger than 1GB | 0                   |                 |

Stereo\_Top\_Right\_po\_104901\_p  
1/16/03, 7:27 PM



# New GXP Xplorer Search Functions ...2

- Updated User Interface (UI) for GXP Xplorer Search within SO CET GXP.
- Selection of database to query has been simplified.
- Data types dynamically change with GXP Xplorer Platform v2.5.3 custom data models.
- Set and store commonly used metadata values for future queries.

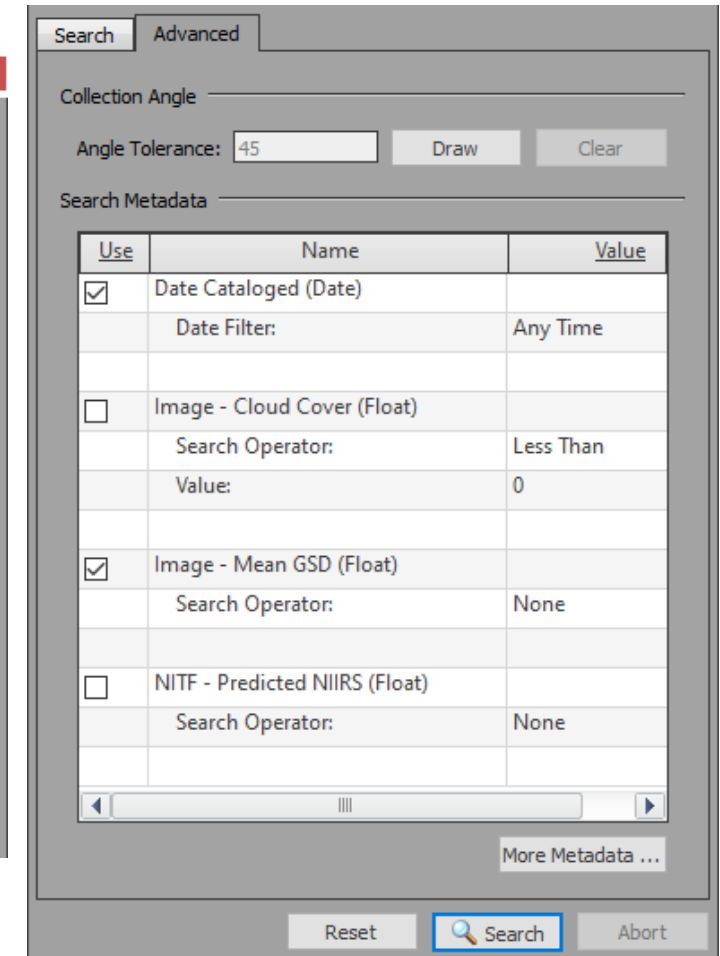
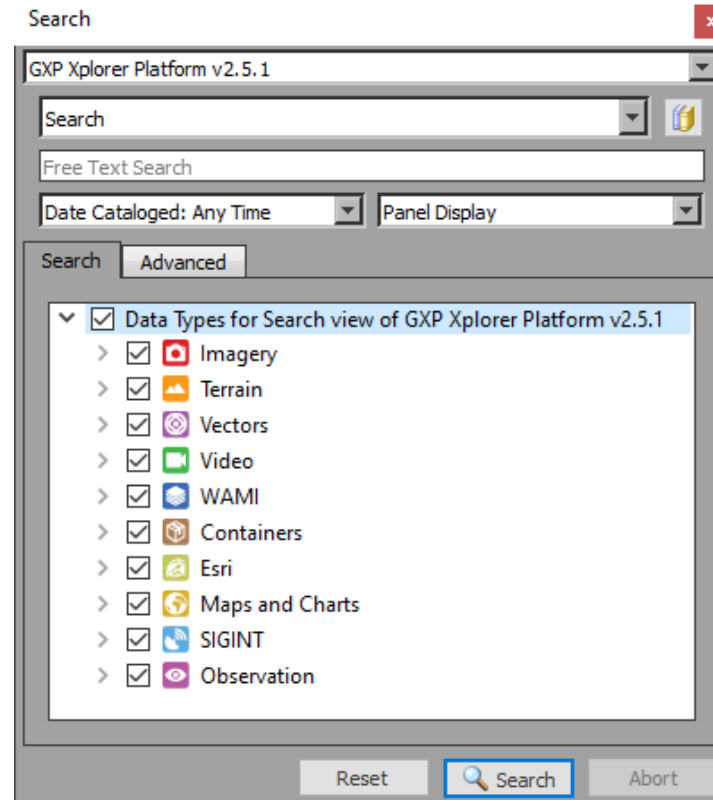

# New GXP Xplorer Search Functions ...3

- Search for ArcGIS provided Feature and MapServers in GXP Xplorer.
- Open discovered services in SOCET GXP Multiport.
- List of available catalogs automatically refreshes.

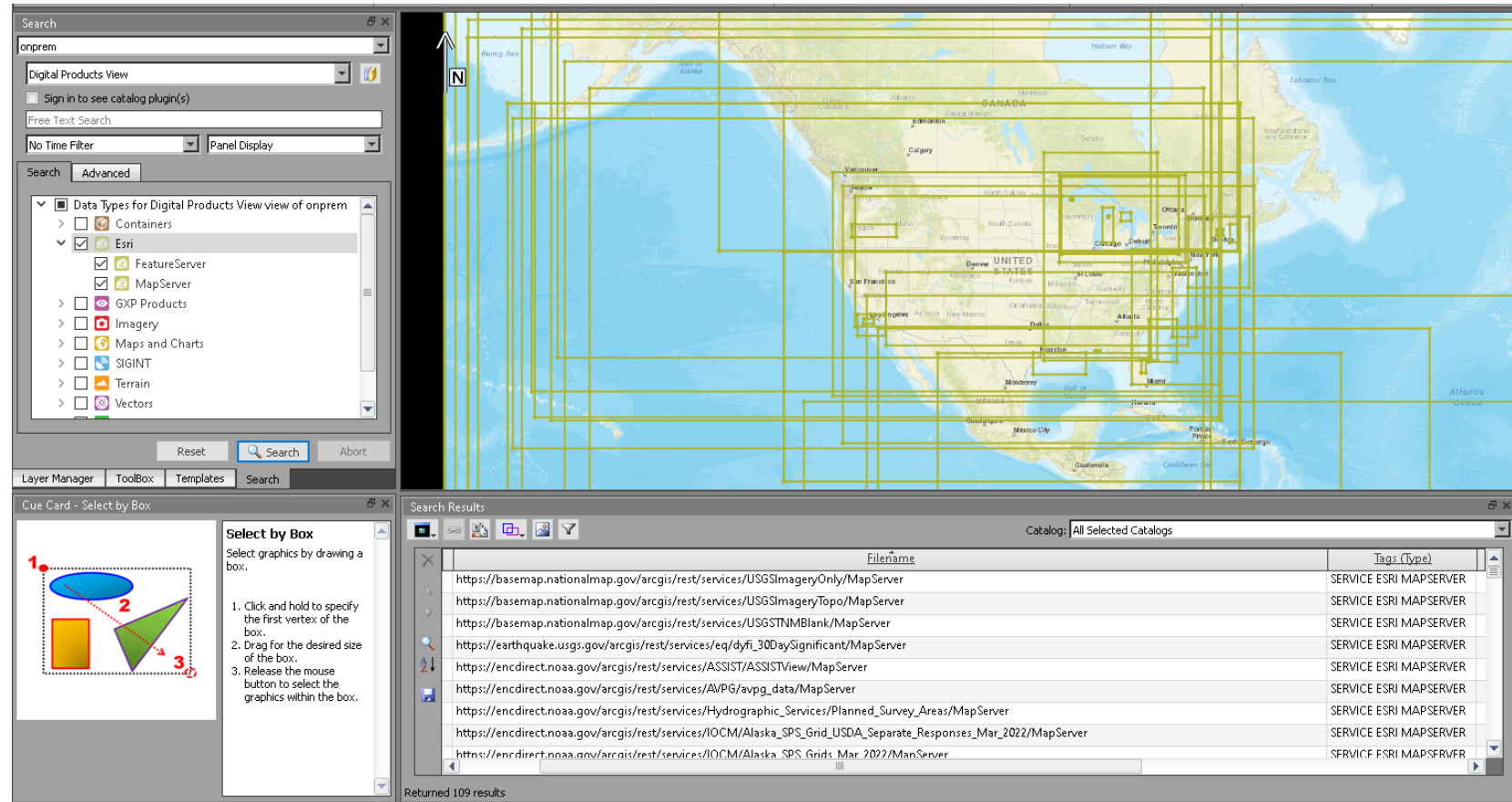

# Access GXP Xplorer Forms from SOCET GXP

- Users can access Forms hosted in GXP Xplorer Platform.
- Forms are loaded directly into the Workflow System View.
- Completed forms can be reviewed in a web browser.

The screenshot displays the GXP Xplorer Platform interface. On the left, a 'Task Queue' table lists tasks with columns for Job ID, Task Name, Description, and Date Created. The task (7737) 'Complete Form Workflow' is selected. The main area shows the 'Task Steps' for this task, including 'Aircraft Type' (Boeing 777), 'Aircraft Count' (13), and 'Date Collected' (2023-12-25 15:16:21). A 'Work Packet' sidebar on the right shows a tree view with folders for 'Source Data', 'Products', and 'Pending Uploads'. At the bottom, there are 'SAVE' and 'MARK COMPLETE' buttons. The interface also includes a 'Map View' tab and a 'Geographic | WGS\_84 | MSL(EGM96)' indicator.

| Job ID | Task Name | Description | Date Created            |
|--------|-----------|-------------|-------------------------|
| (8102) | Comple... |             | Mar 6, 2024, 3:14:31 PM |
| (8023) | Comple... |             | Mar 6, 2024, 3:14:26 PM |
| (7949) | Comple... |             | Mar 6, 2024, 3:14:20 PM |
| (7877) | Comple... |             | Mar 6, 2024, 3:14:15 PM |
| (7807) | Comple... |             | Mar 6, 2024, 3:14:10 PM |
| (7737) | Comple... |             | Mar 6, 2024, 3:14:05 PM |
| (7665) | Comple... |             | Mar 6, 2024, 3:14:00 PM |
| (7593) | Comple... |             | Mar 6, 2024, 3:13:55 PM |
| (7523) | Comple... |             | Mar 6, 2024, 3:13:50 PM |
| (7451) | Comple... |             | Mar 6, 2024, 3:13:45 PM |
| (7349) | Comple... |             | Mar 6, 2024, 3:13:40 PM |
| (7277) | Comple... |             | Mar 6, 2024, 3:13:35 PM |
| (7169) | Comple... |             | Mar 6, 2024, 3:13:29 PM |
| (7061) | Comple... |             | Mar 6, 2024, 3:13:24 PM |
| (6979) | Comple... |             | Mar 6, 2024, 3:13:19 PM |
| (6897) | Comple... |             | Mar 6, 2024, 3:13:14 PM |
| (6815) | Comple... |             | Mar 6, 2024, 3:13:09 PM |
| (6707) | Comple... |             | Mar 6, 2024, 3:13:04 PM |

## Ability to change color of feature when selecting the feature

- Changing color for selecting feature:
  - Choose a color, style and weight.
- Ability to display vertices:
  - Choose a color, style, and weight.
- Moved the Edit Frame display from Configure → Performance Preference location.

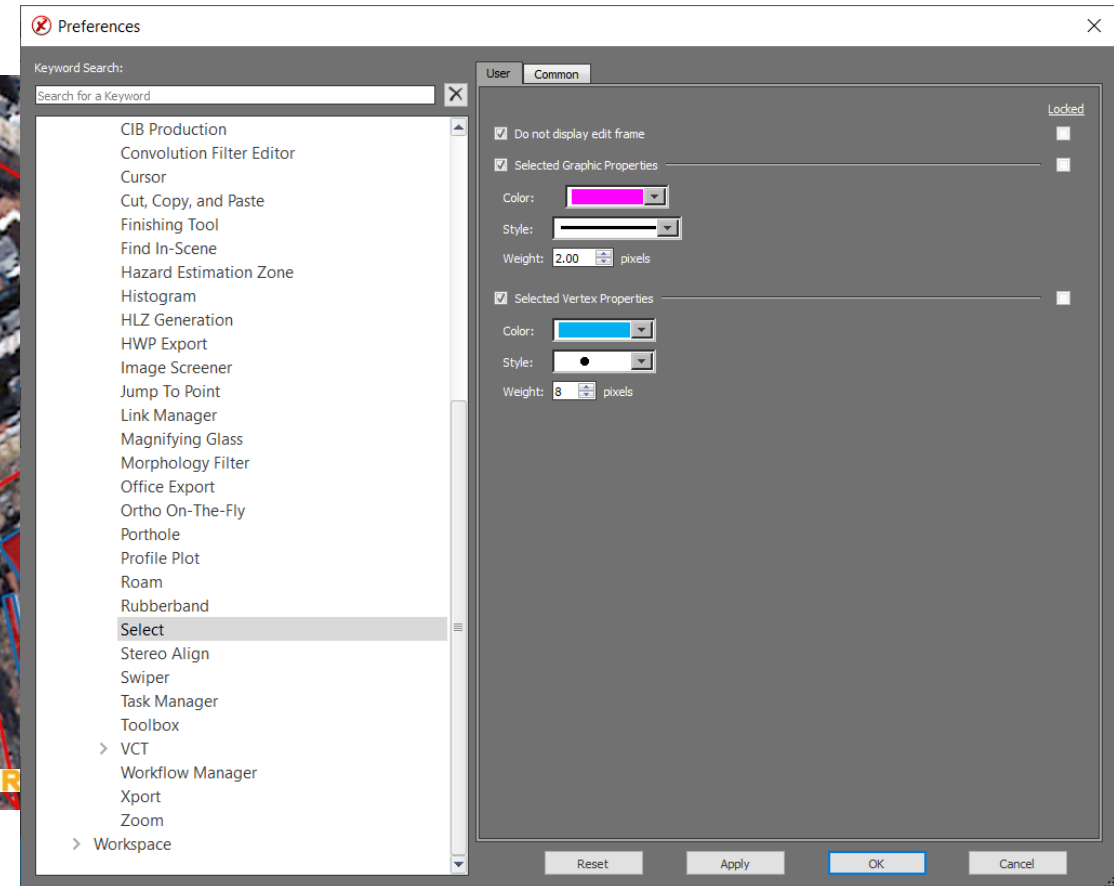

# Ability to change vertex values with Edit Vertices Window

- Changing vertex values in Edit Vertices Window:
  - Ability to change coordinates and elevation values.
  - Highlight a row and jump to vertex.

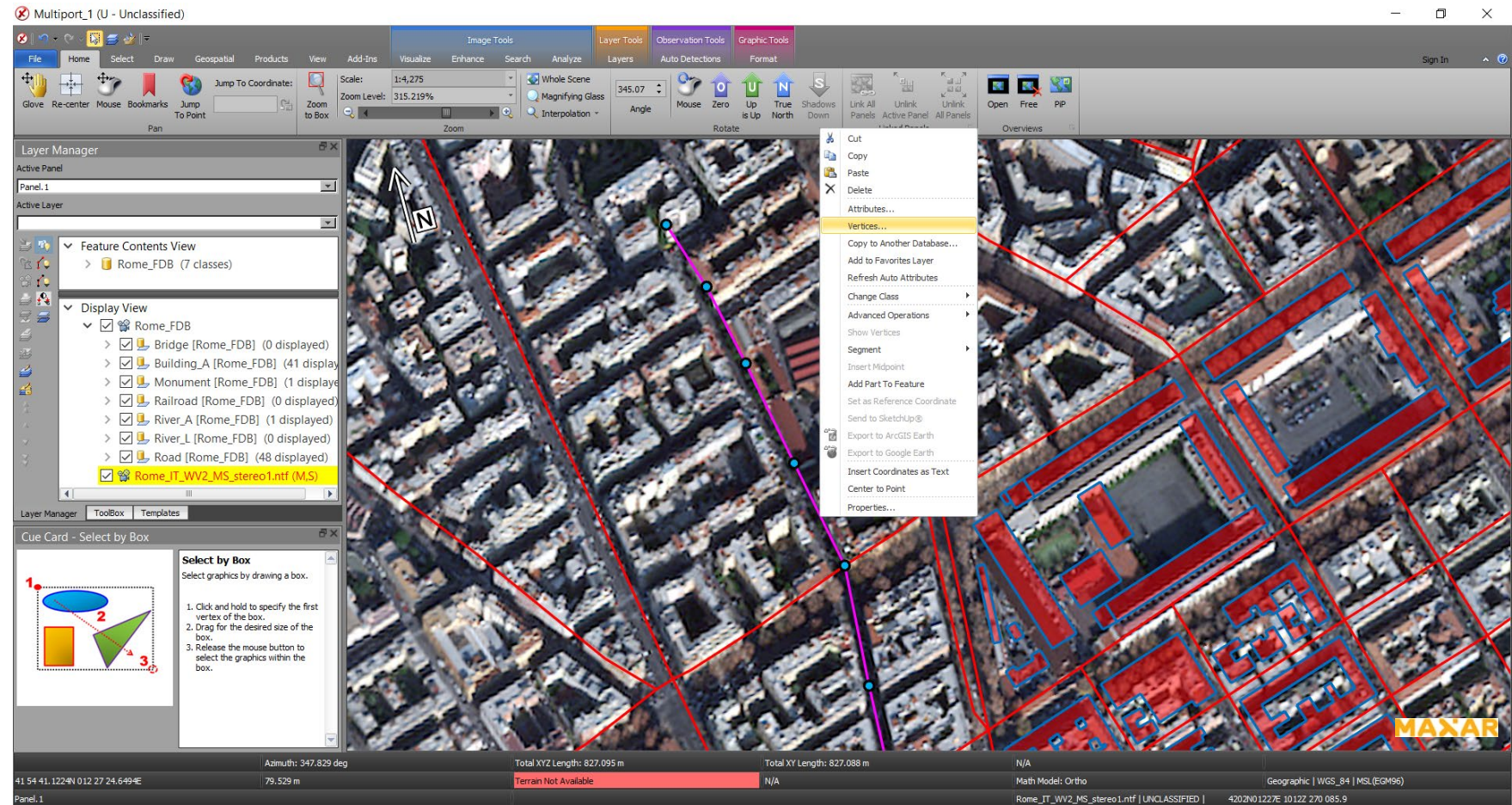

# Hide Empty Layers in a database

- Ability to hide layers in a database that do not have any features collected in them.
  - Toggle On/Off to hide or to show all available feature classes.

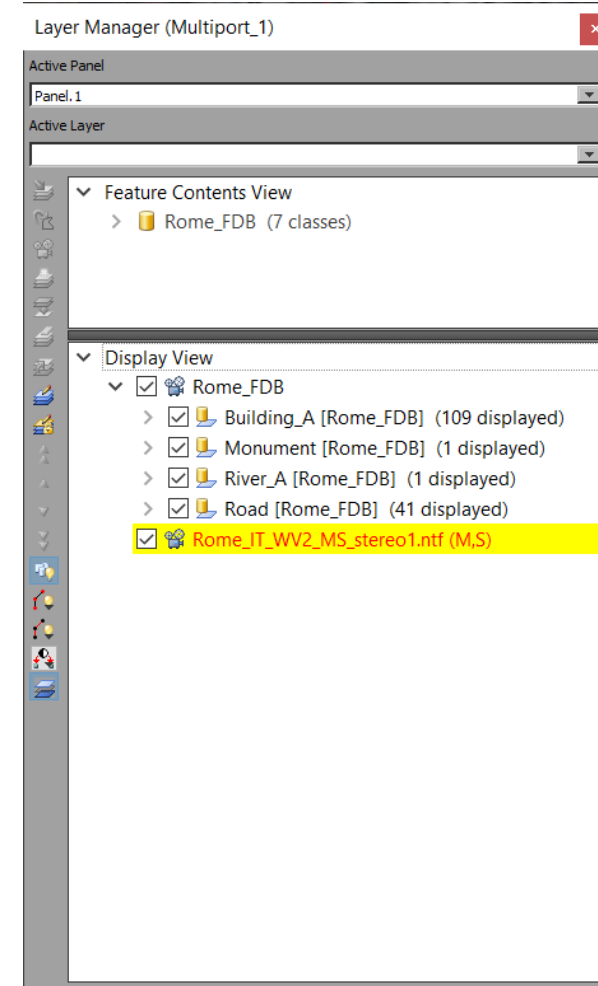
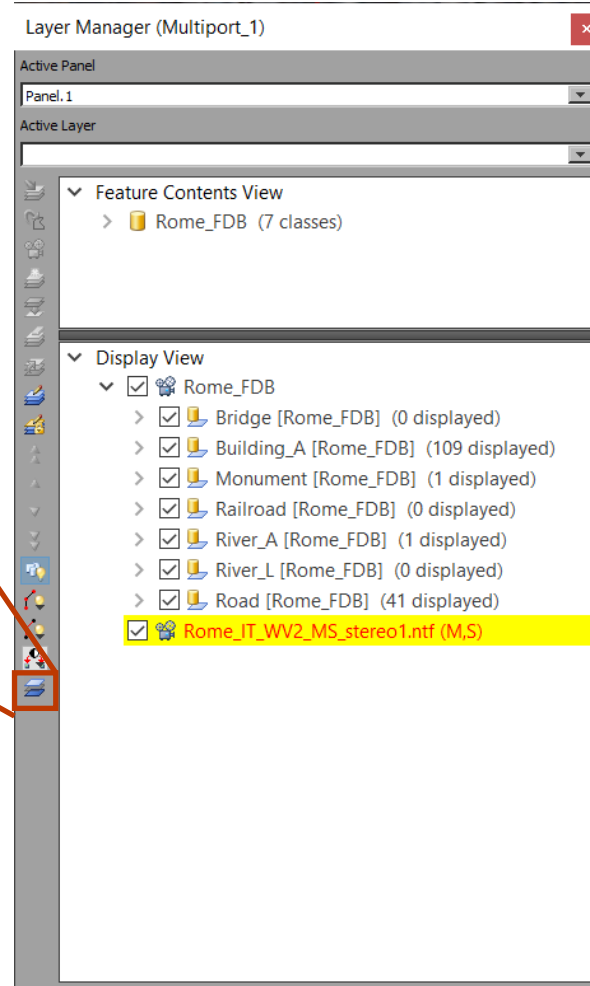

# Feature Attributes Menu

- Enhanced Feature Attribute Window Interaction:
  - Select multiple features from one or more classes.
  - From multiple features, the analyst can set features as active.
  - From multiple features, the analyst can zoom into the selected set.

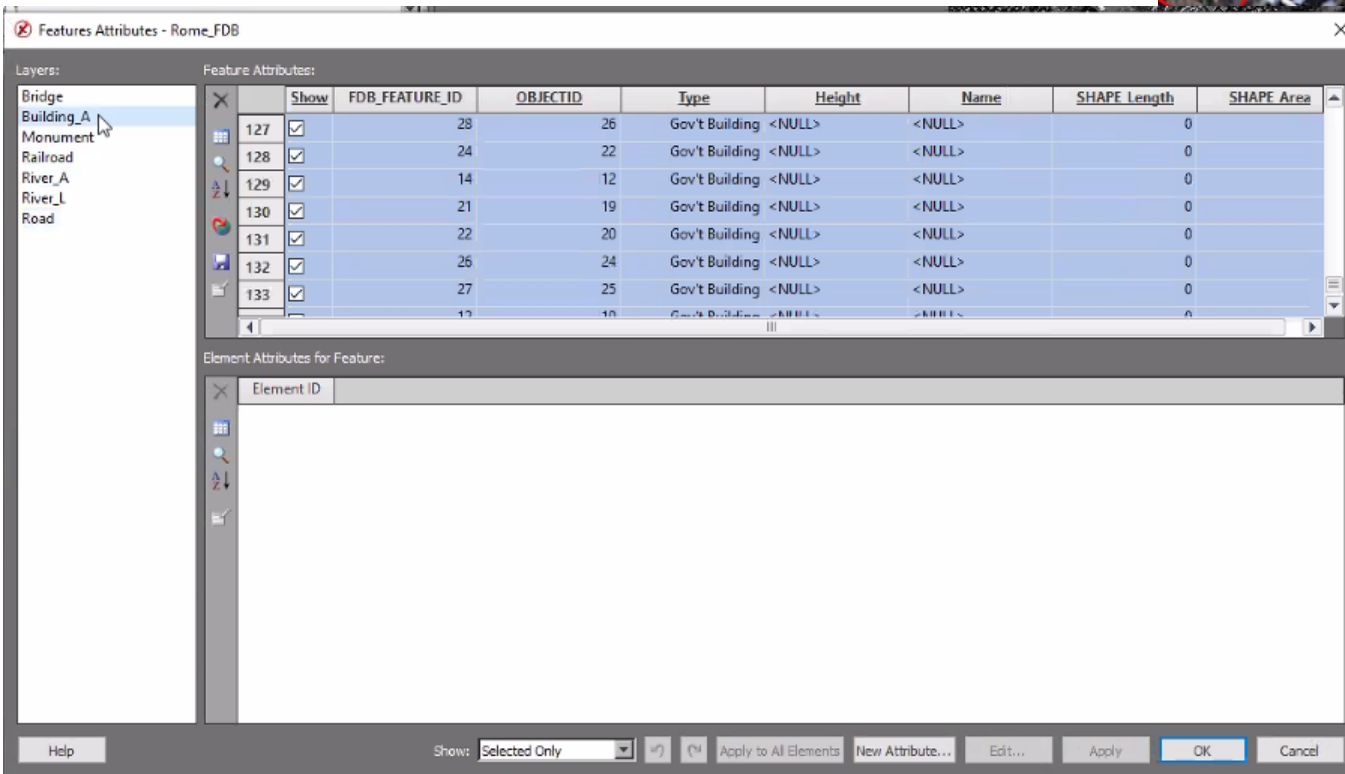

## Ellipse Tool update

- Ability to define the amount of vertices used to create circle.
  - Ellipse tool can create triangle, square, pentagon, hexagon based on the amount of vertices used.

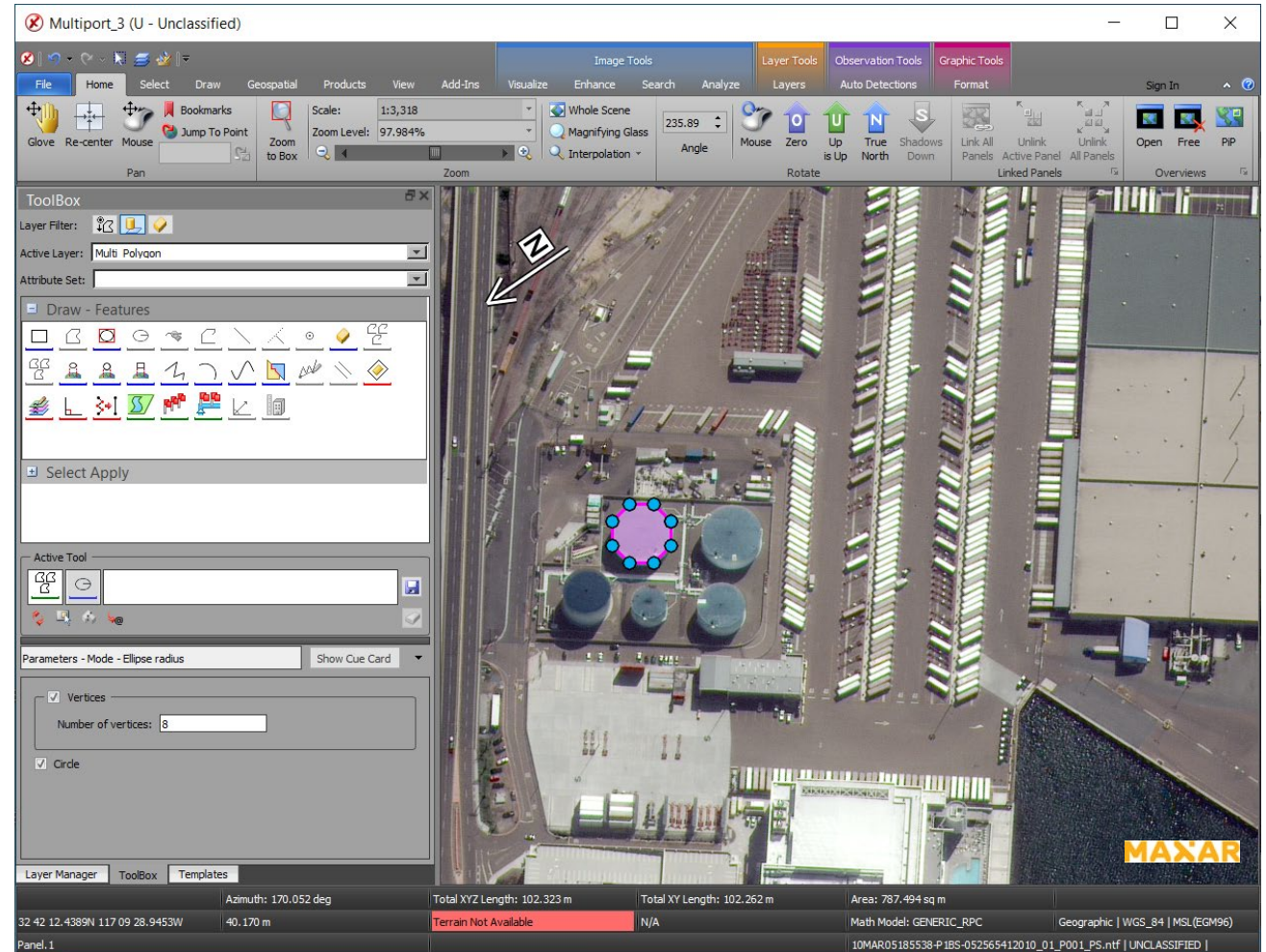



## Vertex Selection priority

- Moving a vertex has been updated to allow only the vertex of the feature selected to move.
  - Very useful when two vertices from different features are sharing same location.



# Transparency for Feature Lines

- Lines in drawn features can now apply transparency.



| Outline   | Fill  | Vertex  |
|---|---|---|
| Line Color: <input type="color" value="#00FF00"/> | Color: <input type="color" value="#00FF00"/>    | Color: <input type="text" value="None"/>      |
| Style: <input type="text" value="Solid"/>         | Pattern: <input type="text" value="None"/>      | Style: <input type="text" value="Dot"/>       |
| Weight: <input type="text" value="2"/> pixels     | Transparency: <input type="text" value="19"/> % | Weight: <input type="text" value="2"/> pixels |
| Transparency: <input type="text" value="50"/> %   |   |   |

# Feature Validation

- User interface for new topology tools and algorithms:
  - Ribbon tab for expansion.
  - Dockable window.
- Features are validated against relevant geometric rules and associated parameters.
- Validation results are displayed and worked off by the analyst.
- Users can save a session to continue work later or share with another user.
- Reparse the specification files without having to reopen SOCET GXP.
- Indicators showing status of error.

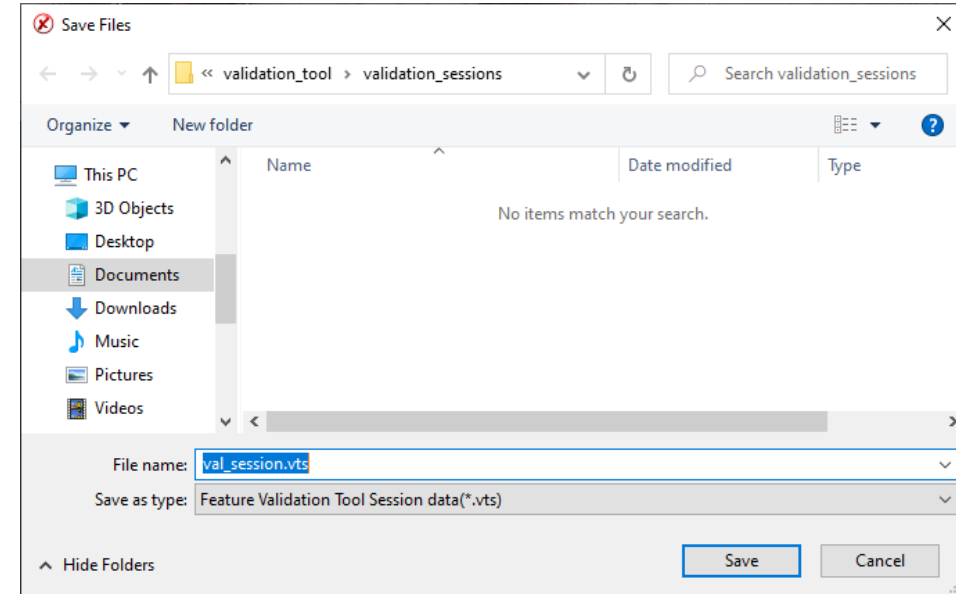
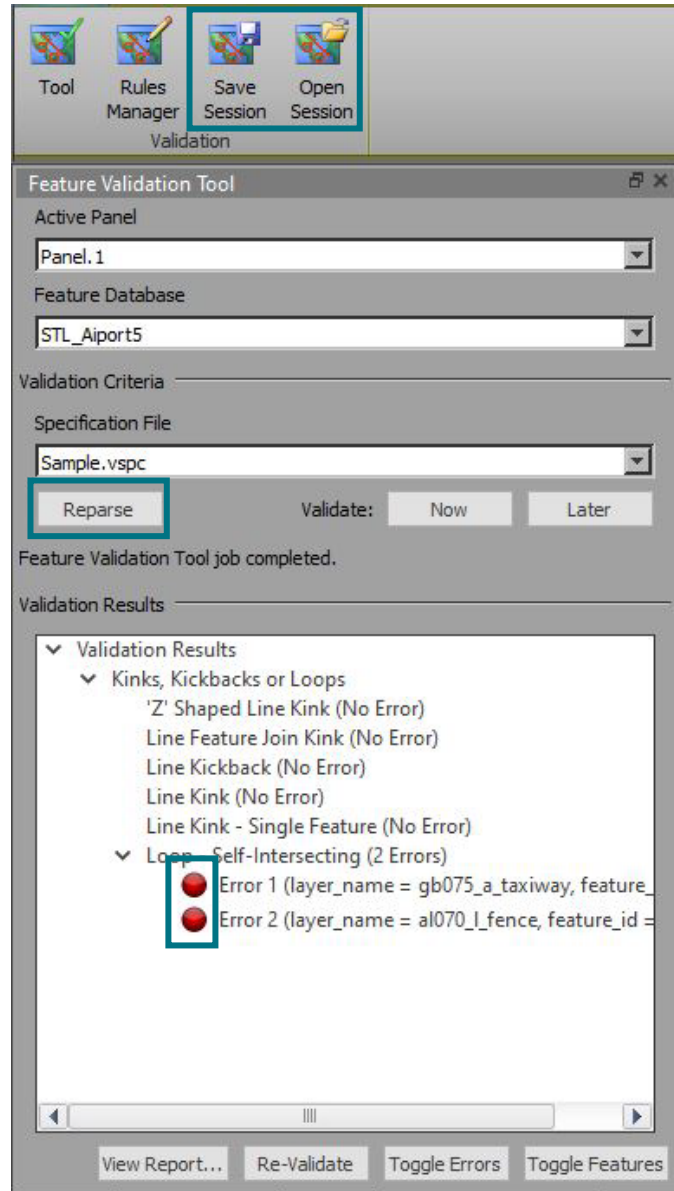

# Medial Axis Auto-attribution

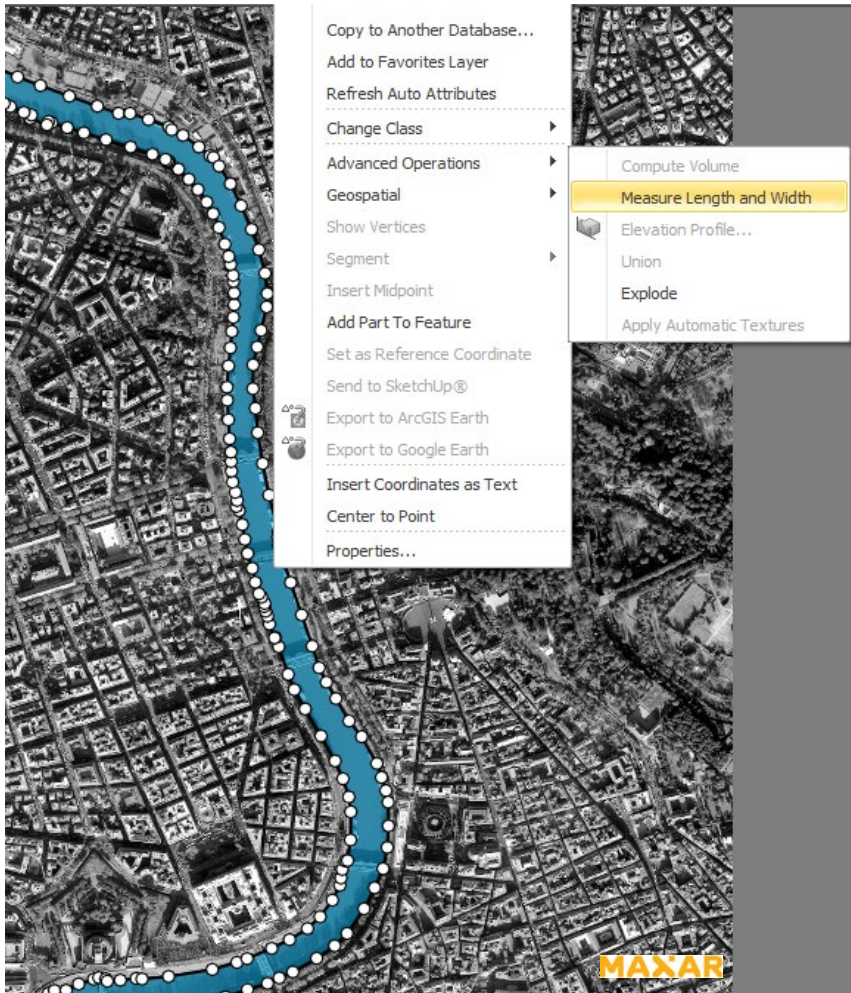

- Right mouse menu function to measure the length and width of a feature.
- Automatically opens Mensuration Log with measurements included.
- Contents of the Mensuration Log can be set in Preferences > Tools > Measure Polygon Length and Width.

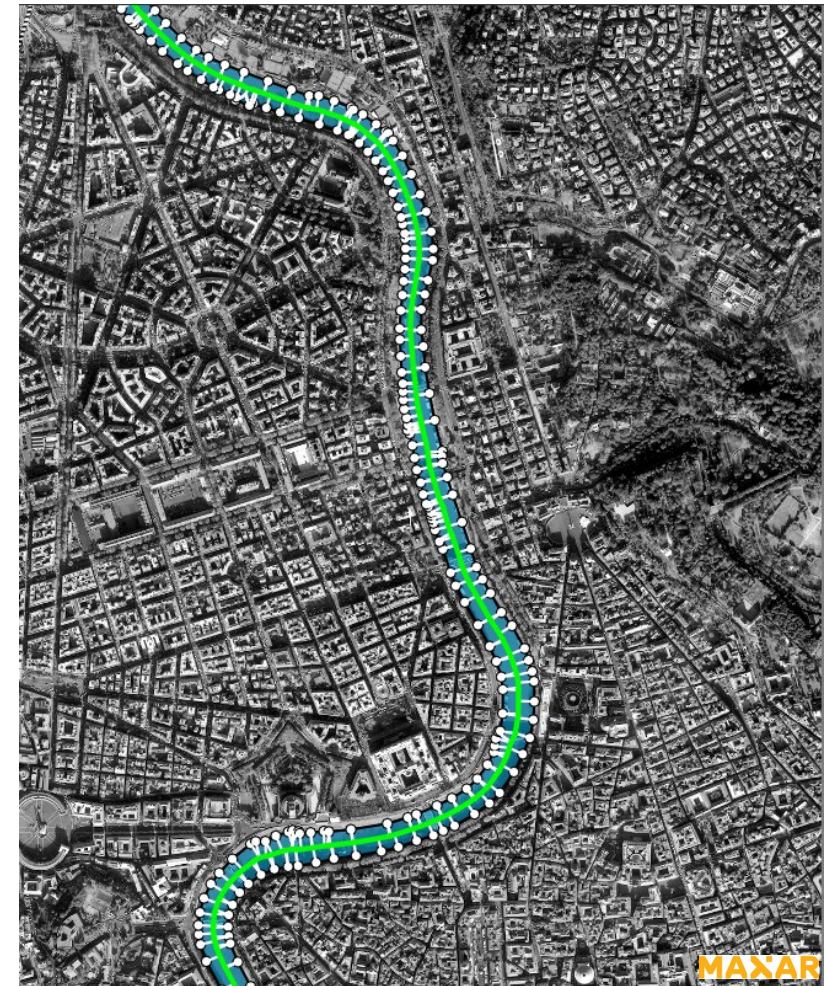
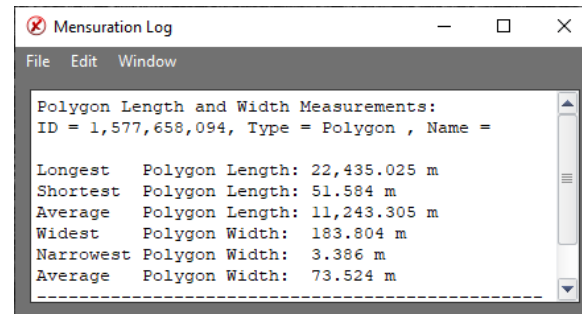

# Depth Measurement Tool

- Mensuration tool for measuring depths of pits, with two methods for measuring slope.
  - Use Terrain to calculate the slope.
  - Manually enter the slope if known.

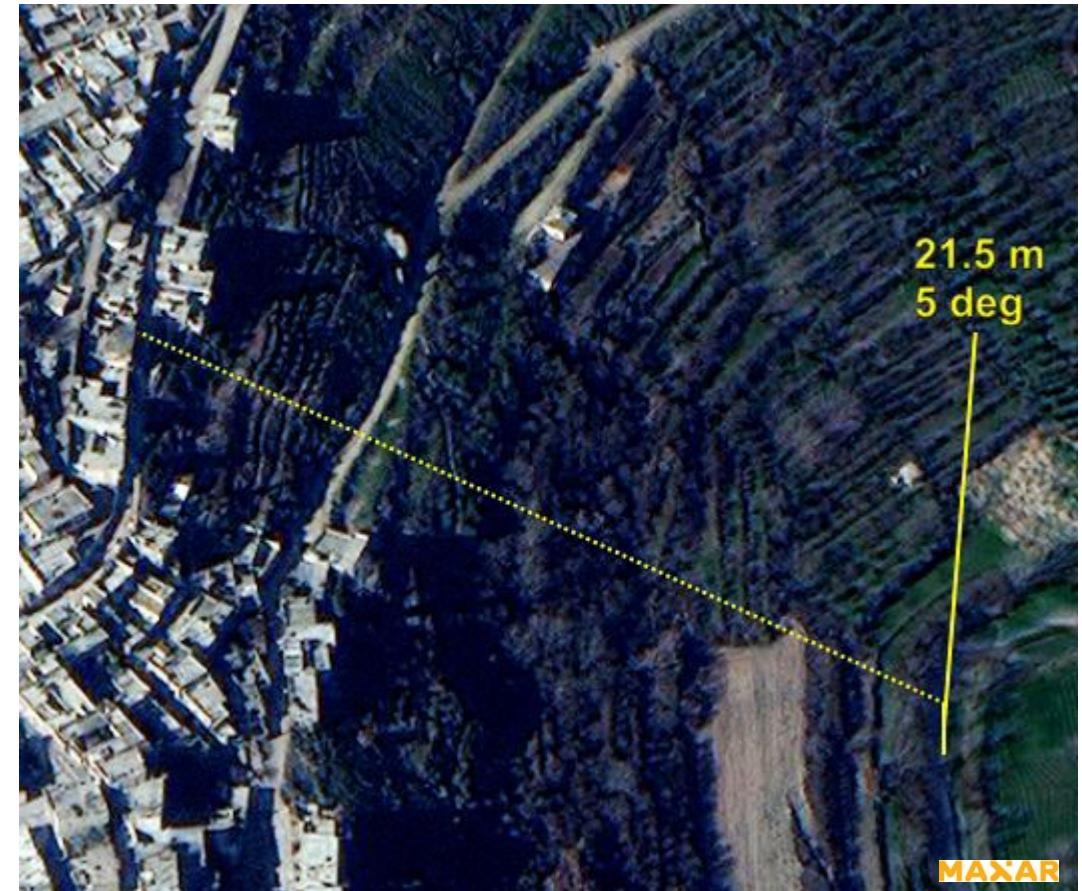
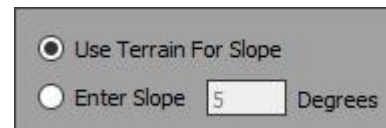
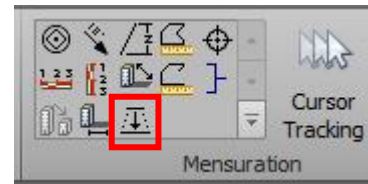

## Drop to Ground Attribute

- Planimetric – Set each vertex to the average terrain Z plus the attribute height value.
- Topographic – Set each feature vertex to the terrain value plus the height attribute value.
- Geomorphic – Set each feature vertex to the ground terrain value.

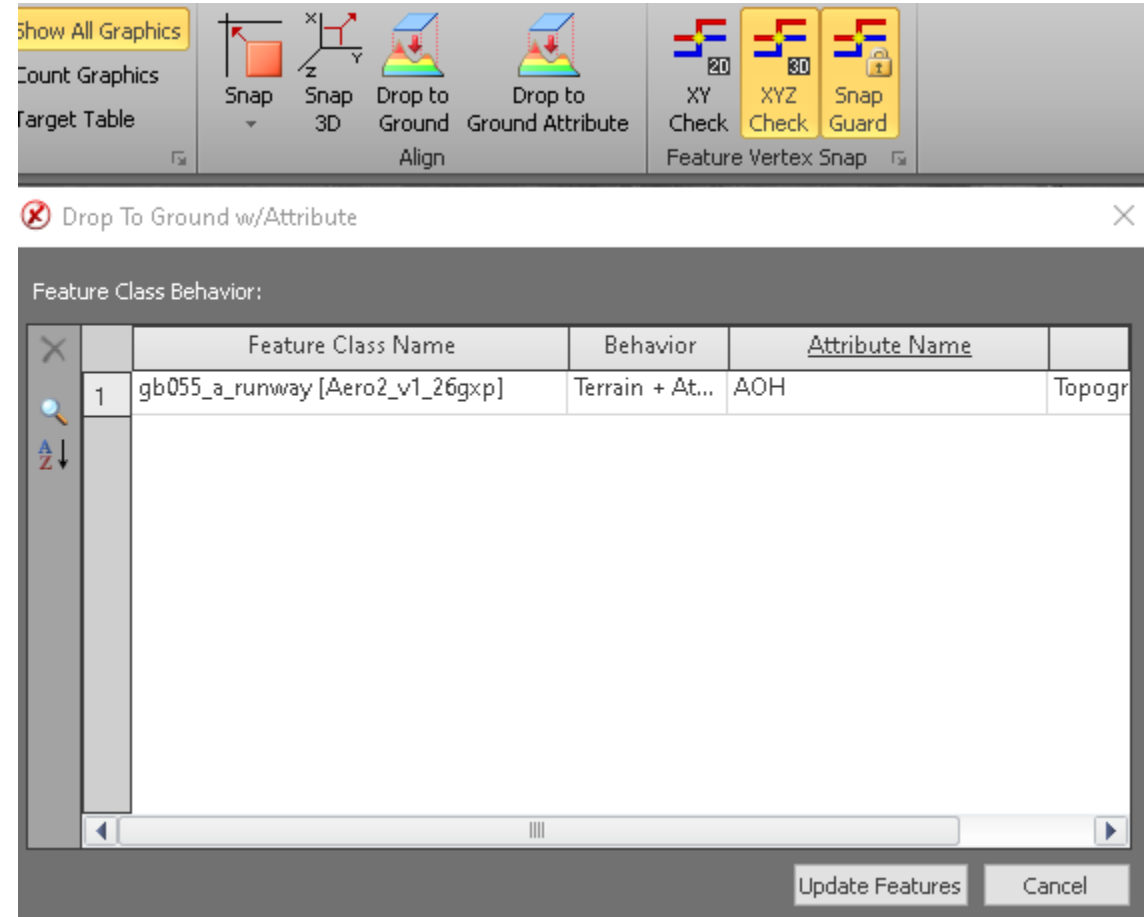

# Terrain Tracking with Z-Offset

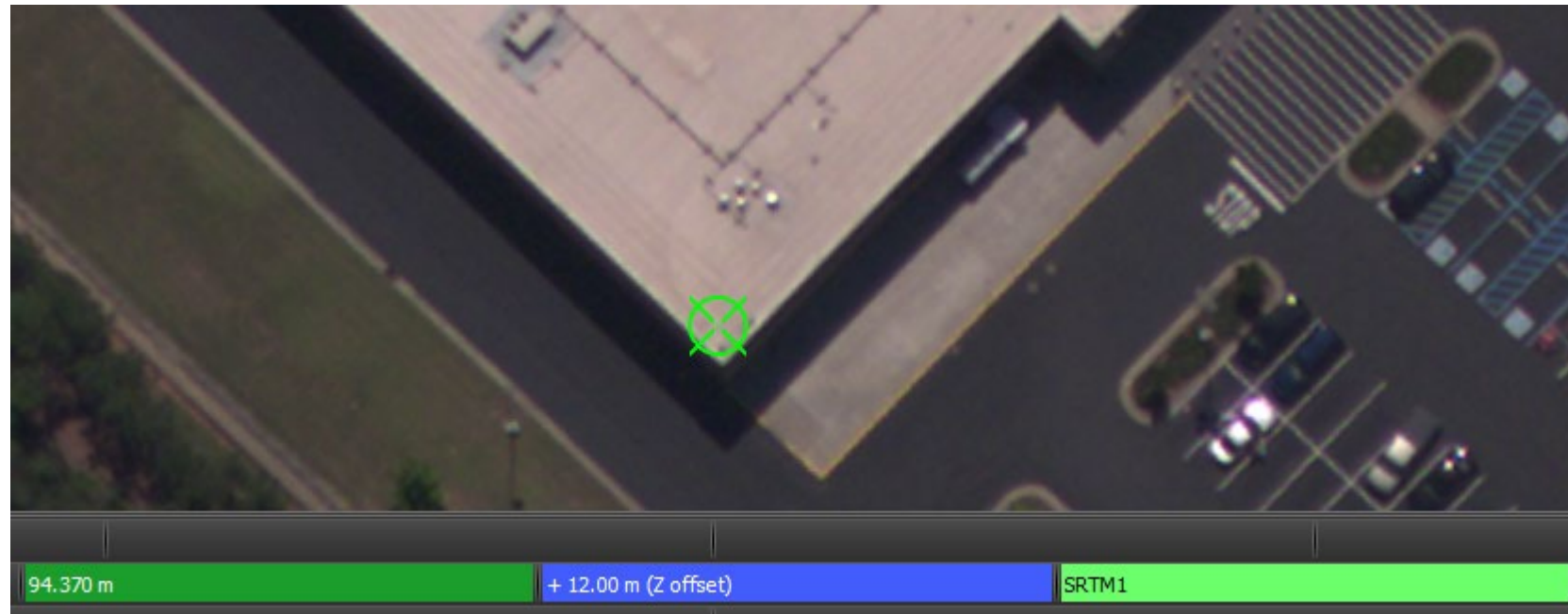
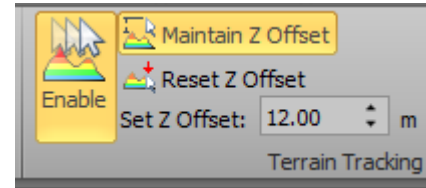

Imagery courtesy of NOAA/NGS.

## Feature Extraction and SOCET for ArcGIS (SFA)

- Enable the view/edit attributes option when multiple features are selected from multiple classes.
- Enhance edit undo/redo capabilities to work with PostGIS and Geodatabase files.
- Graphics drawing performance improvements for SFA Pro when zooming.

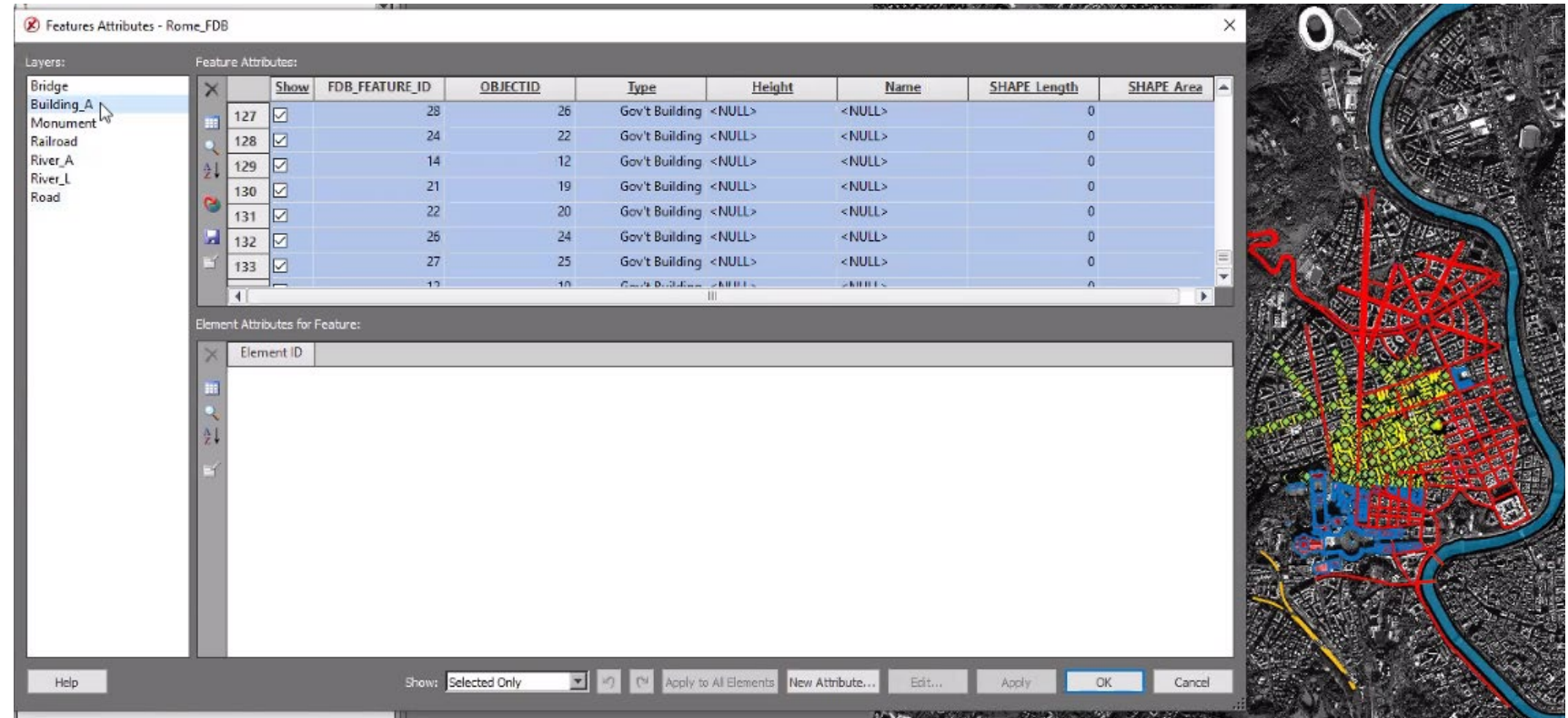

© 2024 Maxar Technologies.



# Structured Observation Management (SOM)

- Provide image chips in JPG or NITF ICHIPB format with observations retaining metadata of the original image in the chip for NITF.
- Apply to All option when editing attributes.

The screenshot displays a GIS application interface. On the left, a 'Layer Manager' window shows a 'Feature Contents View' with several layers, including 'ART Observation'. In the foreground, an 'Observation Feature Attributes' dialog box is open, showing a table of attributes for editing. The 'Apply to All Rows' button is highlighted with a red box. On the right, a satellite map shows a coastal area with a river and a small inset image chip. Below the map is an 'Observation Table' with the following data:

| Show | ID | Facility         | Equipment Class  | Equipment name     | Type   | Image ID         | Registration | Identifier | CC  | Activity  | Head |
|------|----|------------------|------------------|--------------------|--------|------------------|--------------|------------|-----|-----------|------|
| 5    | ✓  | 20 North Isla... | ATTACK AIRCRA... | Test equipment ... | Man... | 08FEB09183209... | 606028       | 304072     | USA | Unloading |      |
| 6    | ✓  | 21 North Isla... | ATTACK AIRCRA... | Test equipment ... | Man... | 08FEB09183209... | 462095       | 398614     | USA | Unloading |      |
| 7    | ✓  | 39 None          | SURFACE WARS...  | Test equipment ... | Man... | 08FEB09183209... | 501620       | 751928     | USA | Repair    |      |
| 8    | ✓  | 26 San Dieg...   | SURFACE WARS...  | Test equipment ... | Man... | 08FEB09183209... | 133667       | 769037     | USA | Refueling |      |
| 9    | ✓  | 25 San Dieg...   | SURFACE WARS...  | Test equipment ... | Man... | 08FEB09183209... | 133667       | 769037     | USA | Refueling |      |
| 10   | ✓  | 30 San Dieg...   | SURFACE WARS...  | Test equipment ... | Man... | 08FEB09183209... | 592007       | 163981     | USA | Refueling |      |
| 11   | ✓  | 7 San Dieg...    | SURFACE WARS...  | Test equipment ... | Man... | 08FEB09183209... | 592007       | 163981     | USA | Loading   |      |
| 12   | ✓  | 6 San Dieg...    | SURFACE WARS...  | Test equipment ... | Man... | 08FEB09183209... | 592007       | 163981     | USA | Loading   |      |
| 13   | ✓  | 37 None          | SURFACE WARS...  | Test equipment ... | Man... | 08FEB09183209... | 592007       | 163981     | USA | Repair    |      |
| 14   | ✓  | 40 None          | SURFACE WARS...  | Test equipment ... | Man... | 08FEB09183209... | 592007       | 163981     | USA | Repair    |      |

Number of observations: 26  
Table Status: Complete

© 2024 Maxar Technologies.

## SOM ...2

- Added the ability to view observations across multiple facilities.
- Allow observations to be collected with a single click.
- Select multiple observations in the observation table to set them to complete.

The screenshot displays the 'Observation Toolbox' interface. On the left, a tree view under 'All Equipment' shows a hierarchy of categories including 'SURFACE WARSHIPS' and 'PATROL SHIPS'. The main area shows a satellite image with yellow and green bounding boxes around specific objects. At the bottom, an 'Observation Table' lists 9 observations with columns for ID, Facility, Equipment Class, Equipment name, Type, Image ID, Registration, Identifier, and CC. The table status is 'Incomplete'.

|   | Show                                | ID  | Facility            | Equipment Class | Equipment name     | Type    | Image ID        | Registration | Identifier | CC  |
|---|-------------------------------------|-----|---------------------|-----------------|--------------------|---------|-----------------|--------------|------------|-----|
| 1 | <input checked="" type="checkbox"/> | 235 | San Diego North     | SURFACE WARS... | Test equipment ... | Man...  | 10MAR0518564... | 592007       | 163981     | USA |
| 2 | <input checked="" type="checkbox"/> | 236 | San Diego Secondary | SURFACE WARS... | Test equipment ... | Man...  | 10MAR0518564... | 592007       | 163981     | USA |
| 3 | <input checked="" type="checkbox"/> | 237 | San Diego Secondary | SURFACE WARS... | Test equipment ... | Rece... | 10MAR0518564... | 133667       | 769037     | USA |
| 4 | <input checked="" type="checkbox"/> | 238 | San Diego Secondary | SURFACE WARS... | Test equipment ... | Rece... | 10MAR0518564... | 133667       | 769037     | USA |
| 5 | <input checked="" type="checkbox"/> | 239 | San Diego Secondary | SURFACE WARS... | Test equipment ... | Rece... | 10MAR0518564... | 592007       | 163981     | USA |
| 6 | <input checked="" type="checkbox"/> | 240 | San Diego Secondary | SURFACE WARS... | Test equipment ... | Rece... | 10MAR0518564... | 592007       | 163981     | USA |
| 7 | <input checked="" type="checkbox"/> | 241 | San Diego Secondary | PATROL SHIPS    | Test equipment ... | Rece... | 10MAR0518564... | 747955       | 881427     | USA |
| 8 | <input checked="" type="checkbox"/> | 242 | San Diego Secondary | PATROL SHIPS    | Test equipment ... | Rece... | 10MAR0518564... | 747955       | 881427     | USA |

Number of observations: 9  
Table Status: ● Incomplete

# SOM ...3

- When using the GXP Xplorer Platform as the observation database, SO CET GXP will dynamically load the equipment list from GXP Xplorer Platform.
- When querying GXP Xplorer Platform for observations, results will have icons identical to those in the GXP Xplorer interface.
- Load Observations from GXP Xplorer in a new Multiport directly from the search results.

The screenshot displays the GXP Xplorer interface. At the top is a toolbar with various icons for configuration, observation, and analysis. Below the toolbar is a search panel on the left with a search bar and a tree view of equipment classes. The main area shows an aerial satellite view of a city with several blue icons overlaid on buildings. At the bottom, an 'Observation Table' displays the following data:

|   | Show                                | Equipment Class* | Equipment Name* | Registration | Type   | Activity         | Heading*         | Classification | Status   |
|---|-------------------------------------|------------------|-----------------|--------------|--------|------------------|------------------|----------------|----------|
| 1 | <input checked="" type="checkbox"/> | Water            | Unknown         |              | Manual | Refueling        | 184.877379834609 | Unclassified   | Complete |
| 2 | <input checked="" type="checkbox"/> | Site Element     | Unknown         |              | Manual |                  | 184.4660404135   | Unclassified   | Complete |
| 3 | <input checked="" type="checkbox"/> | Water            | Unknown         |              | Manual | Loading          | 163.06474746007  | Unclassified   | Complete |
| 4 | <input checked="" type="checkbox"/> | Air              | Unknown         |              | Manual | Parked,Refueling | 96.595429086396  | Unclassified   | Complete |

Number of observations: 4  
Table Status: Complete

## SOM ...4

- Users can now collect observations by point, polyline, polygon, and rectangle without changing configuration files.
- Selections are dynamic and allow users to collect multiple geometries into the same database.

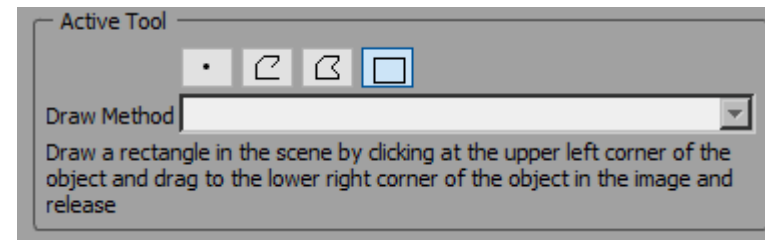
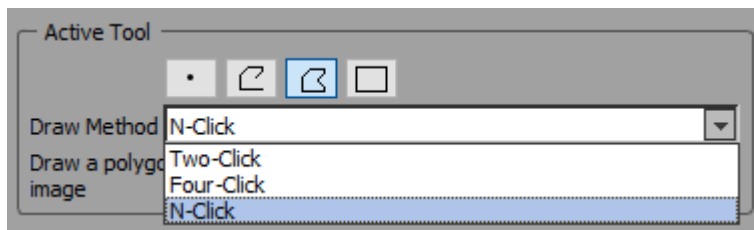
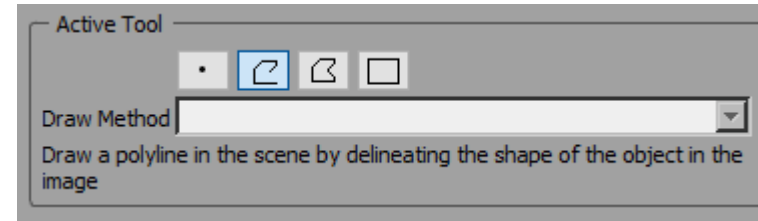
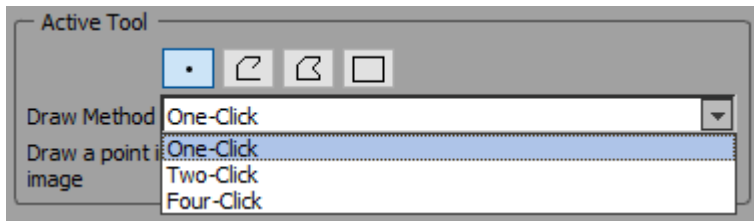

# Export to Microsoft® Word

Export products to Microsoft® Word directly from SOCET GXP.

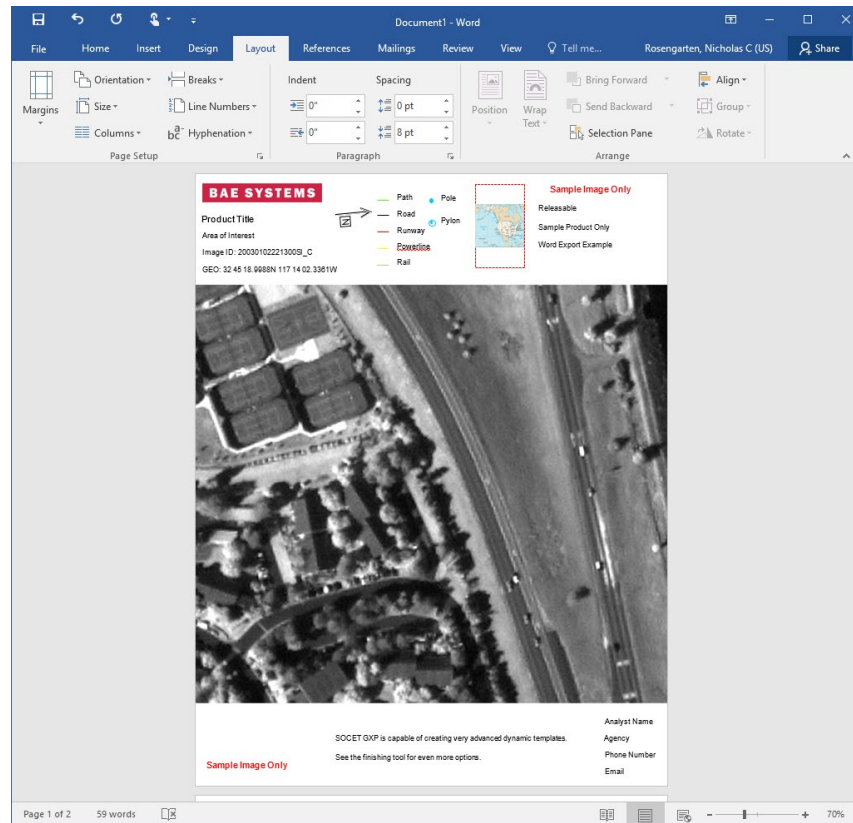

© 2024 Maxar Technologies.

- Preference added to allow the format to be portrait or landscape.
- Users can also export to Hangul Word Processor.
- License product creation in Microsoft Word under the SOCET GXP GeoElement bundle and above.

# Export Multi-panel Multiport to PowerPoint®

- Users can export multiple templated panels to PowerPoint®.
- They can be edited and adjusted once exported.

PowerPoint export

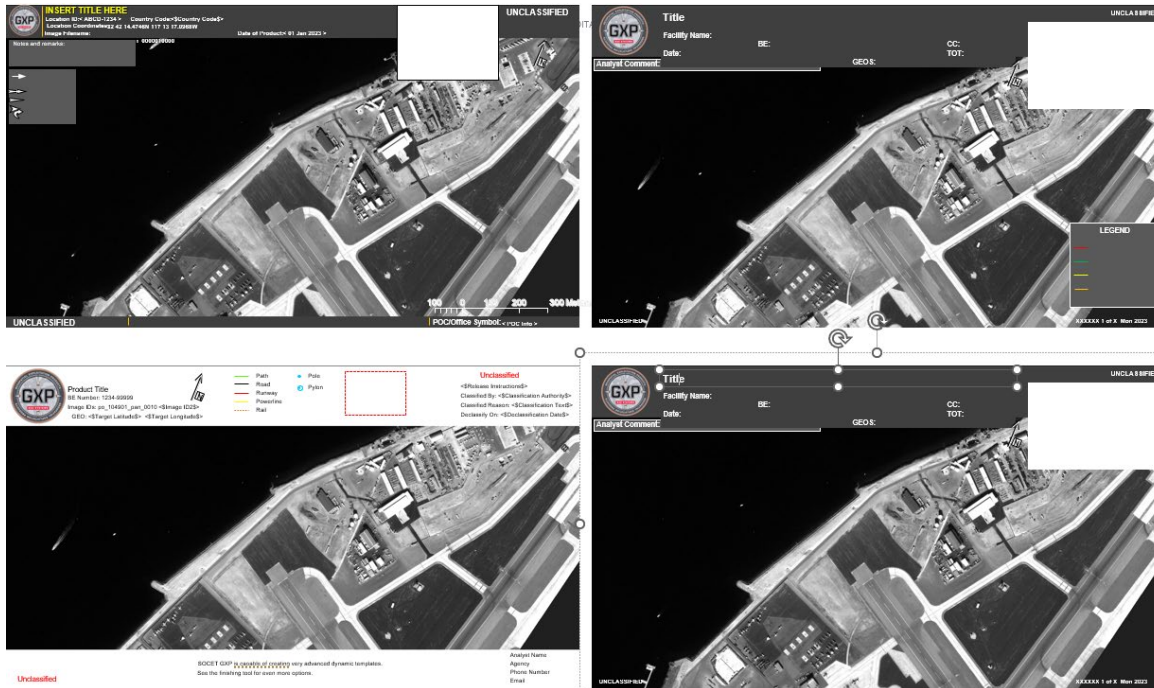

SOCET GXP prior to export

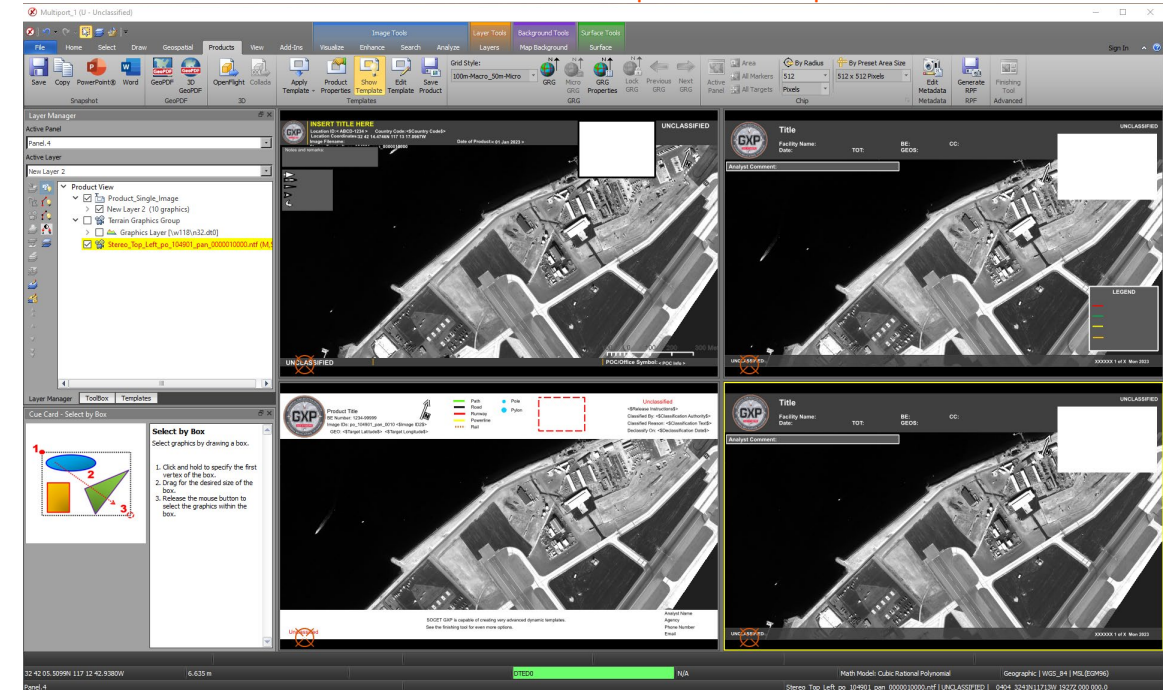

© 2024 Maxar Technologies.

# Non-Ortho GeoPDF

- SO CET GXP can now output GeoPDF without orthorectifying.
- Intended for products derived from Full Motion Video.

Original output



FMV Frame Courtesy of Scan Eagle

New output

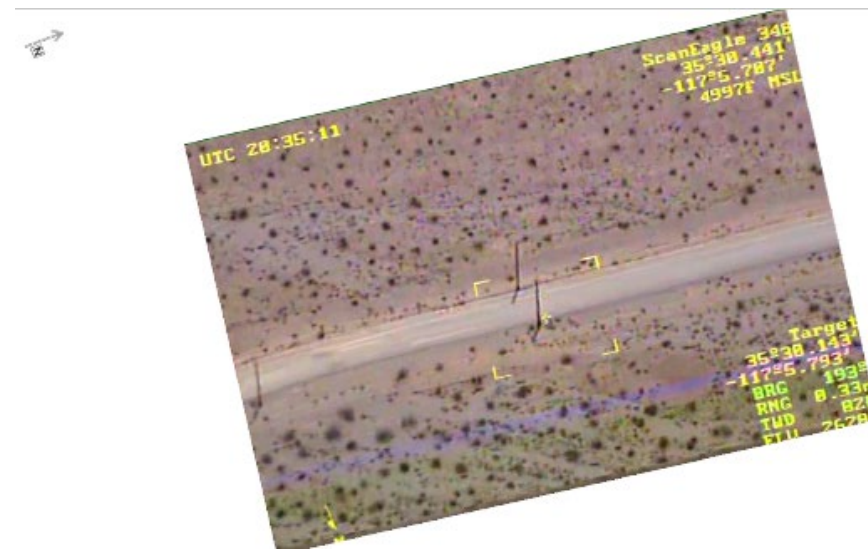

# Videos for SOCET GXP products

Create Video Templates in the SOCET GXP Finishing Tool and PowerPoint.

- Video Player with video controls integrated into the SOCET GXP Multiport.
- Embed Videos in the Finishing Tool and PowerPoint from SOCET GXP animations exported as MPEG.

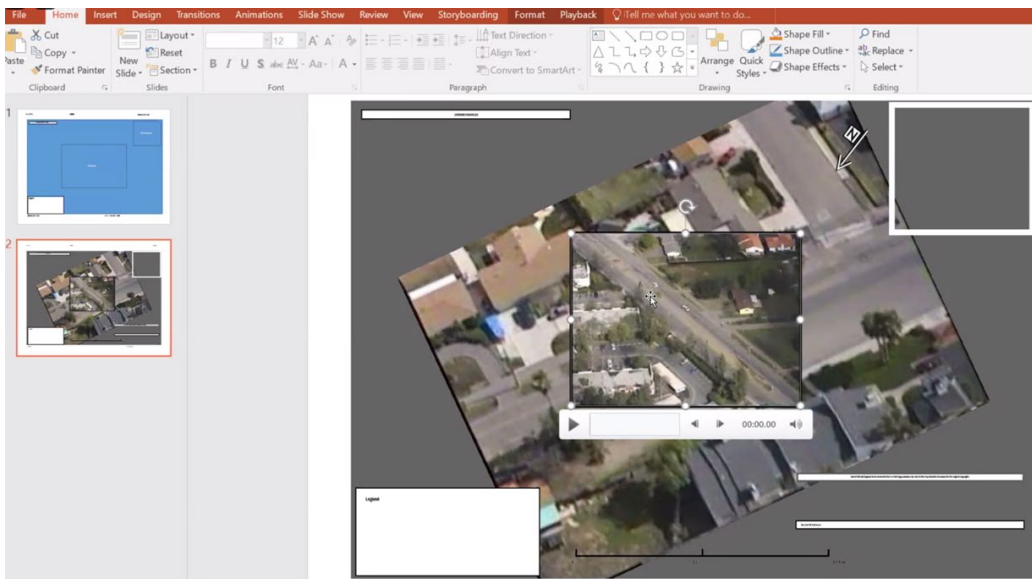

Imagery of MX-15 videos over Ft. Collins, CO; Courtesy of L-3 Communications, EO/IR Inc.

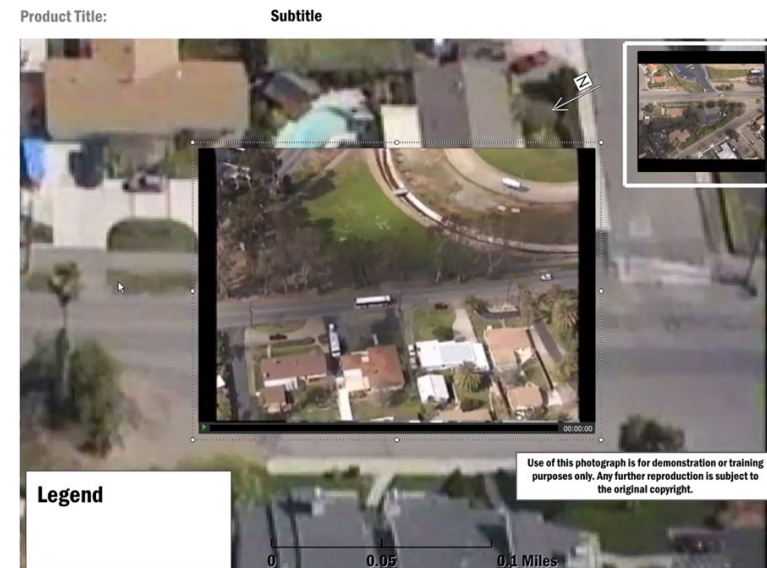



# Keyhole Markup Language (KML) updates

- Added support for KML ScreenOverlays.
  - These are non-ground based features for overlays such as legends and icons, which are not fixed to a ground location.
- Improved support for OGC® standards
  - KMLs generated by the GXP Xplorer Platform will now open properly.

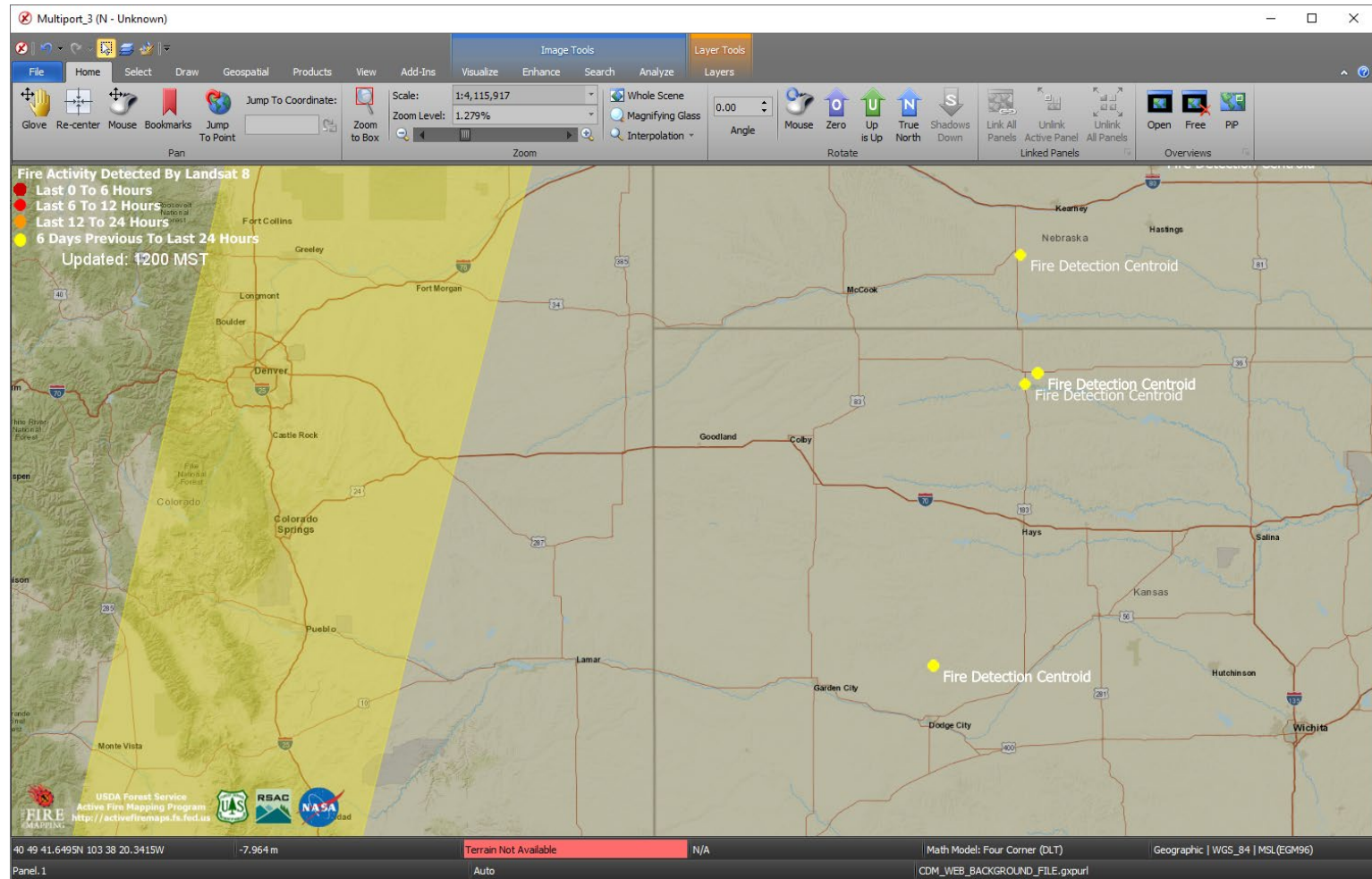

# Updates for Cesium 3-D Tiles® v1.0

- Cesium 3-D Tiles v1.0 is a format for highly detailed geospatial models adapted by the OGC Cesium <https://cesium.com/3d-tiling-pipeline/>.
- SOCET GXP provides support for allowing visualization, roaming, fly-through in the SOCET GXP 3D Multiport.
- Drape Annotations and Features on 3-D Tiles.
- Improved cursor linking available for 3D to 2D Multiports.

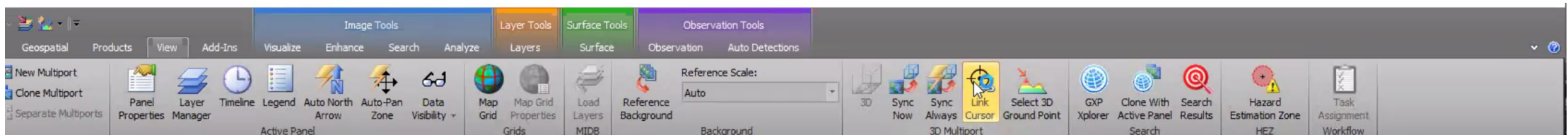
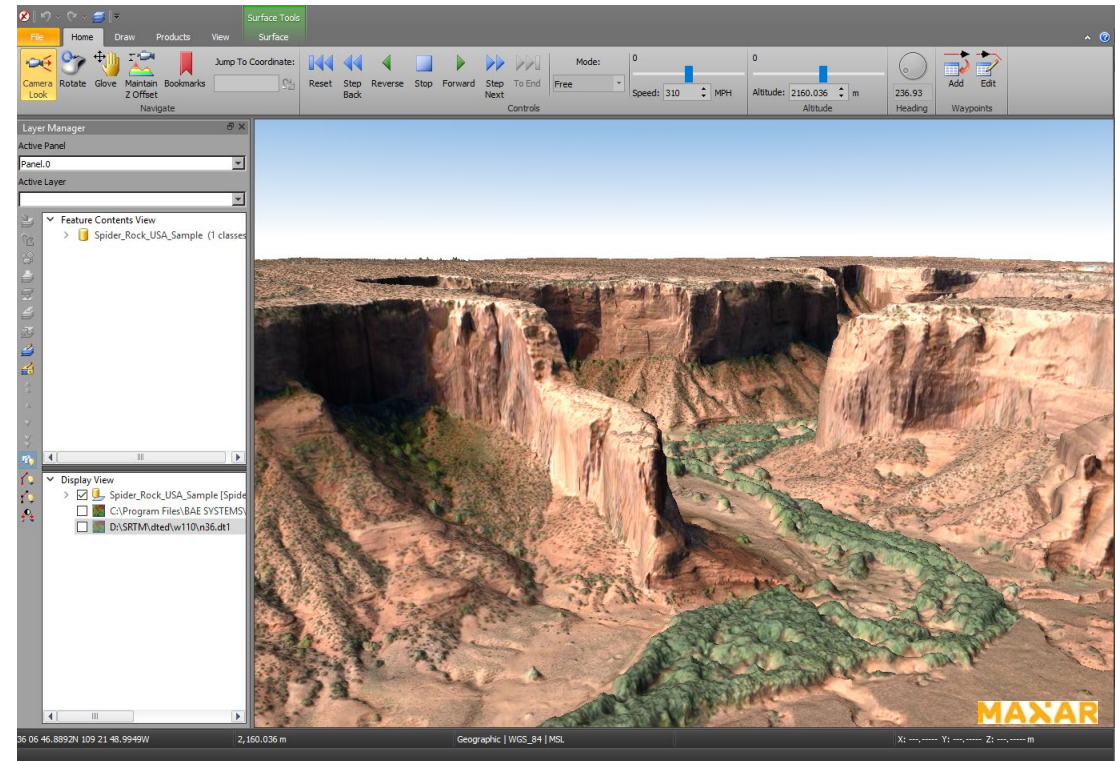

# Updates for Cesium 3-D Tiles v1.0 ...2

- Support streaming services for 3-D Tiles from a URL.
- Option to record animation and fly-thru as MPEG.

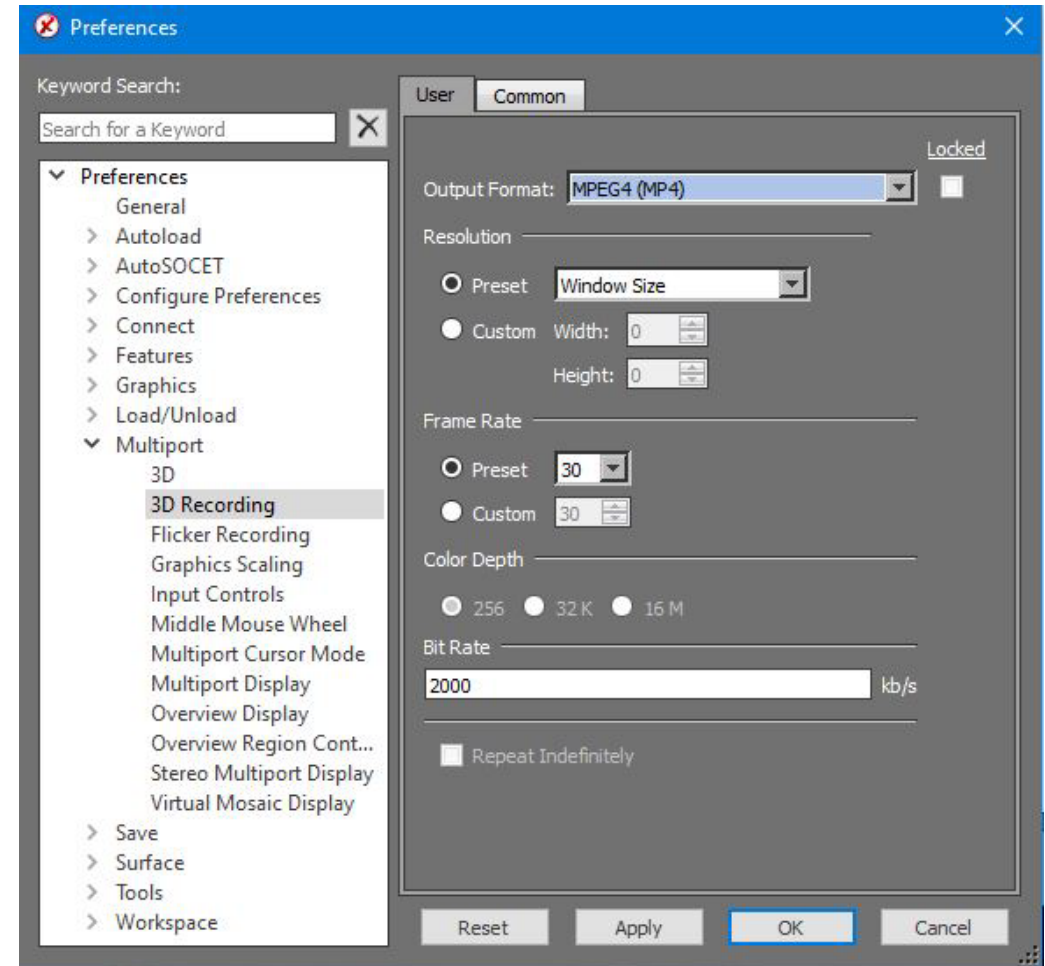
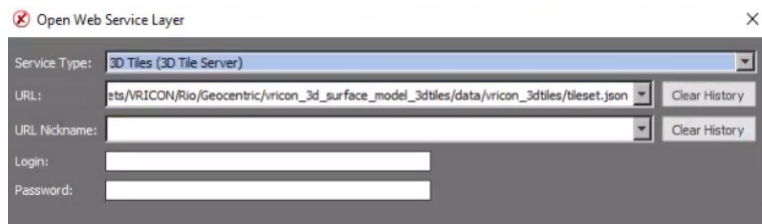

# Registration for 3-D tile mesh

- Register 3-D tile mesh (tileset.json) to imagery in a 2D Multiport.
  - Enables a 3-D tile mesh dataset to be translated in x,y or x,y,z to align with imagery from other sources.
  - Works with stereo Multiport.

Transformation Type: 3D (1 point minimum)

Select from Available Panels

Registration List

|   | Master                              | Selected Panels   |
|---|-------------------------------------|-------------------|
| 1 |                                     | 3D                |
| 2 | <input checked="" type="checkbox"/> | Multiport_6,Pa... |

Align to Master

Input Points

| Point ID | Coordinates               | Elev    | Point Type | 3D                                  | tiport_6,Pa...                      |
|----------|---------------------------|---------|------------|-------------------------------------|-------------------------------------|
| 1        | Pt0001 18S UJ 25479 06566 | 6.497 m | XY Control | <input checked="" type="checkbox"/> | <input checked="" type="checkbox"/> |

# Link Stereo Multiports with 2D/3D Multiports

- Link Stereo, Mono, and 3D Multiports.
- Uses the SOCET GXP link manager for 2D and Stereo linking.

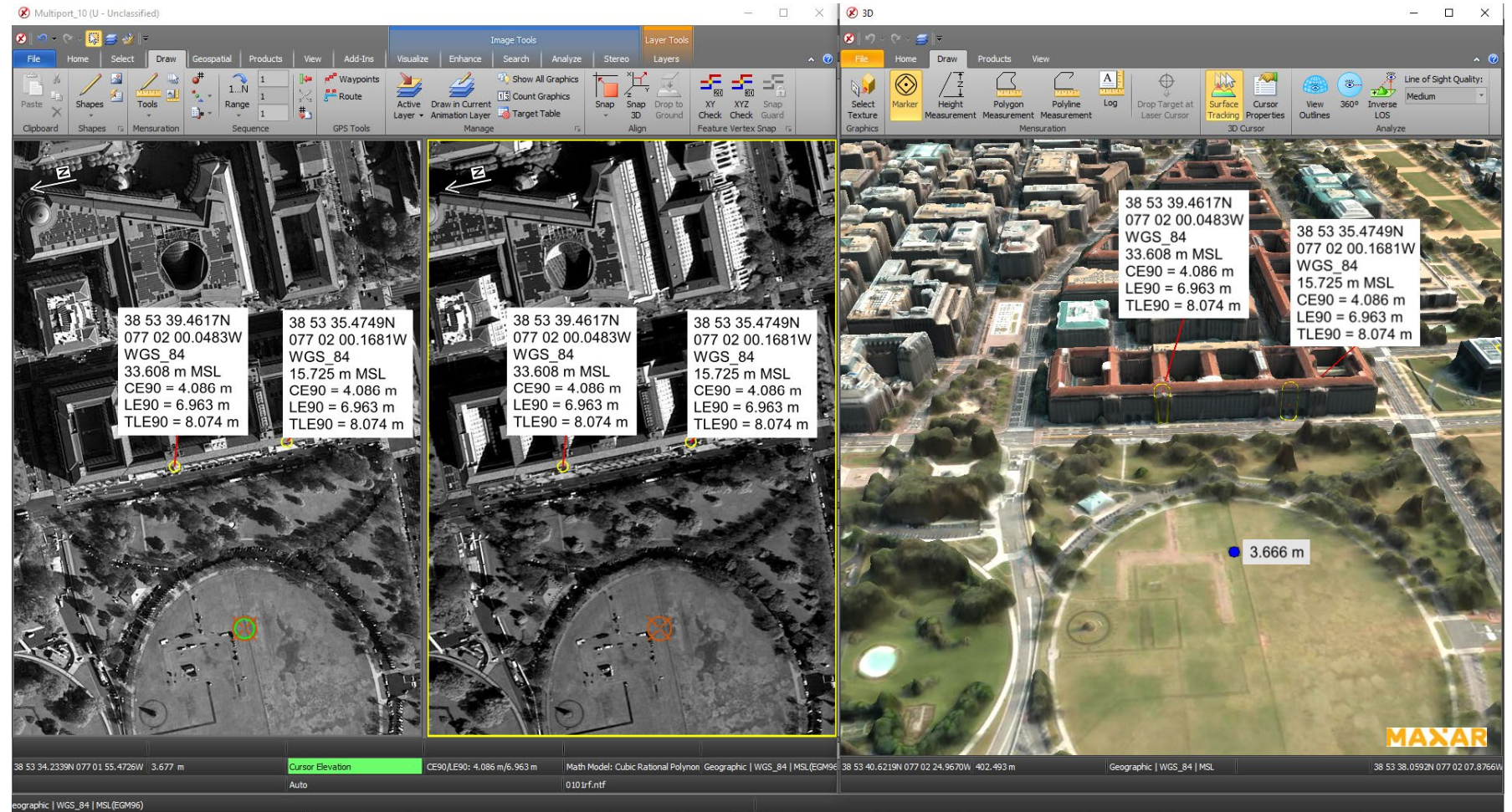

# Application Programming Interface (API) support for 3D Multiport

- API calls can now be made to the 3D Multiport, some examples include:
  - Open and load data into a 3D multiport.
  - Link with a 2D Multiport.
  - Draw graphics.
  - Export products.

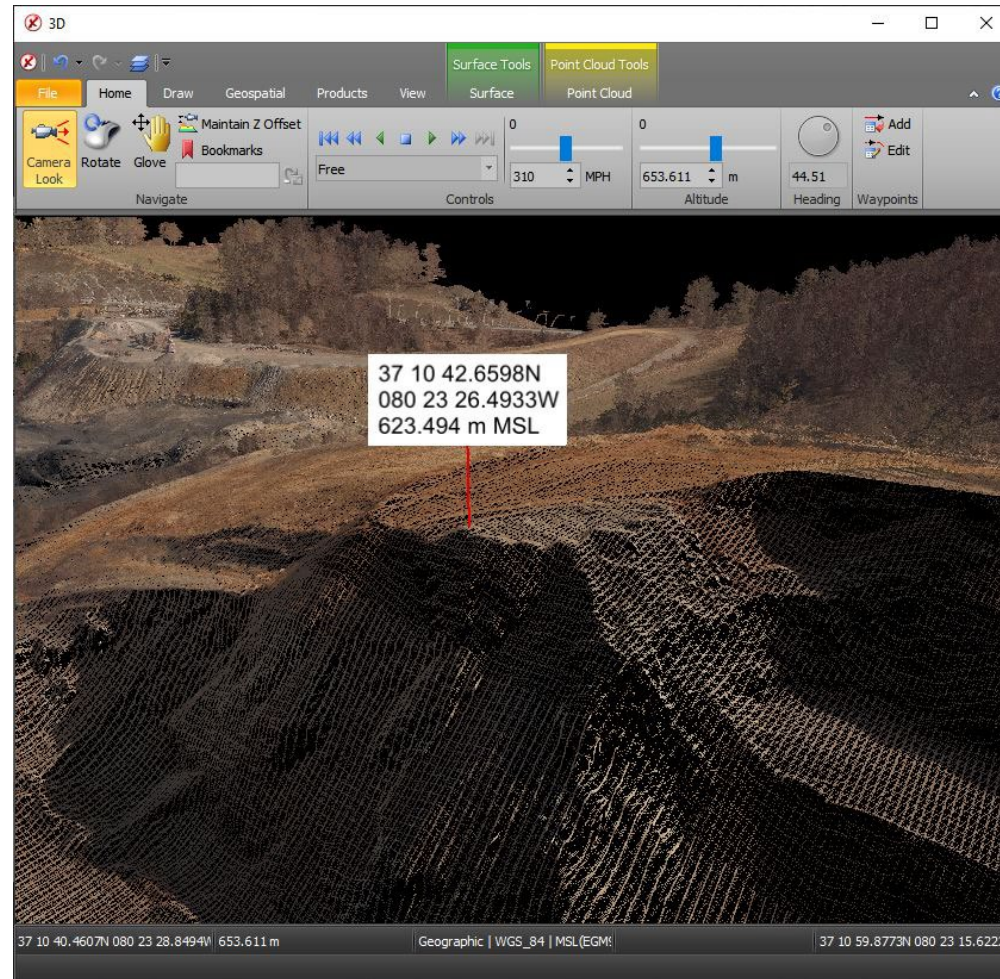

# Multi-Polygon support for Interactive Terrain Editing (ITE)

- Multi-Polygons in ITE allow tools such as lake fill to flatten the lake surface while allowing islands within the lake to retain the original collected surface.

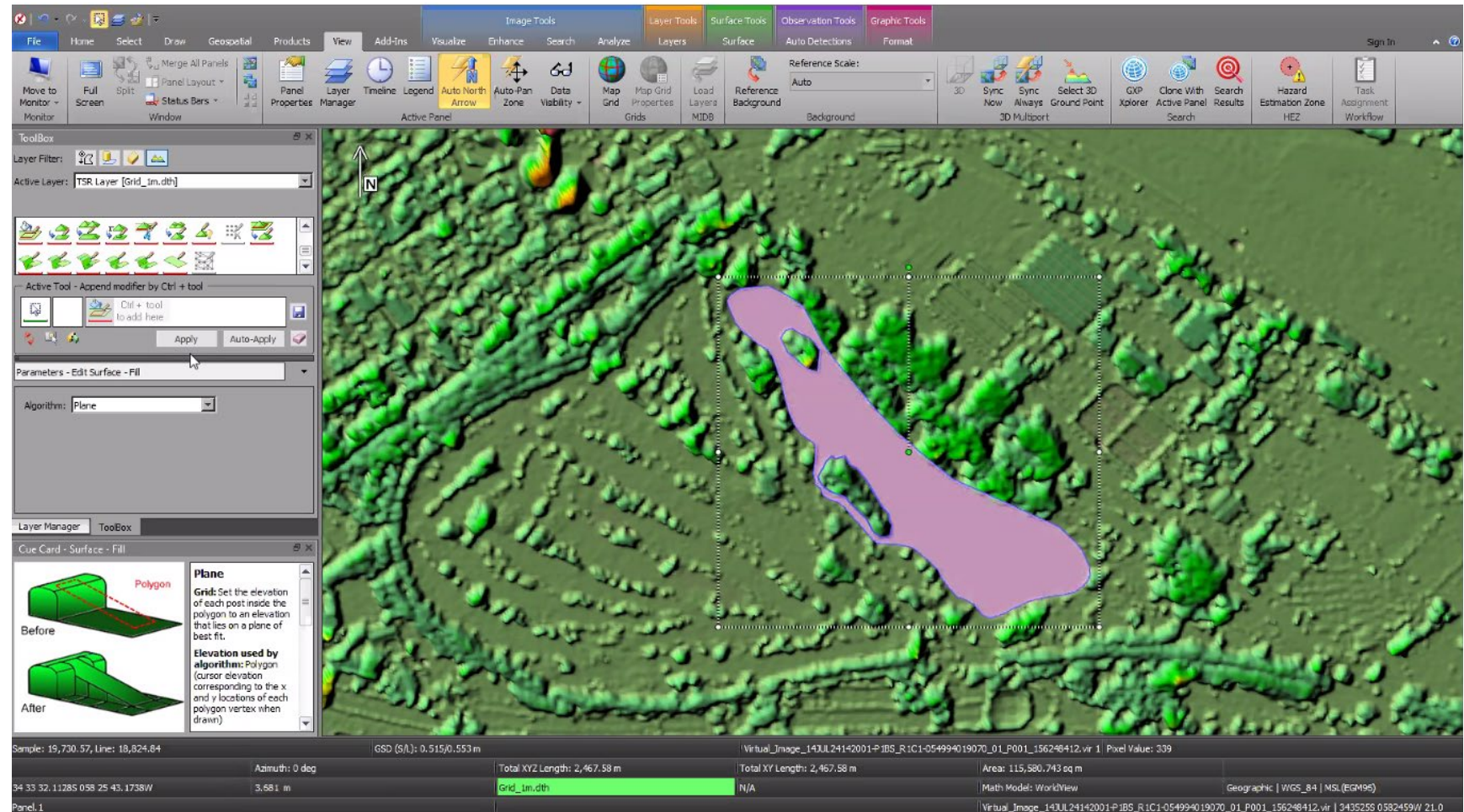

## Edit a Grid Terrain file with Triangulated Irregular Network (TIN) tools in ITE

- Define a Region of Interest (ROI) for editing a Grid Terrain File with TIN Tools.
- The ROI is automatically defined to be consistent in elevation with the grid for a seamless merge back into the grid when editing is finished.
- The ROI can be automatically populated with mass points from the grid or blank.
- Use breaklines and mass points to populate the ROI along with polygon tools such as delete mass points, etc.

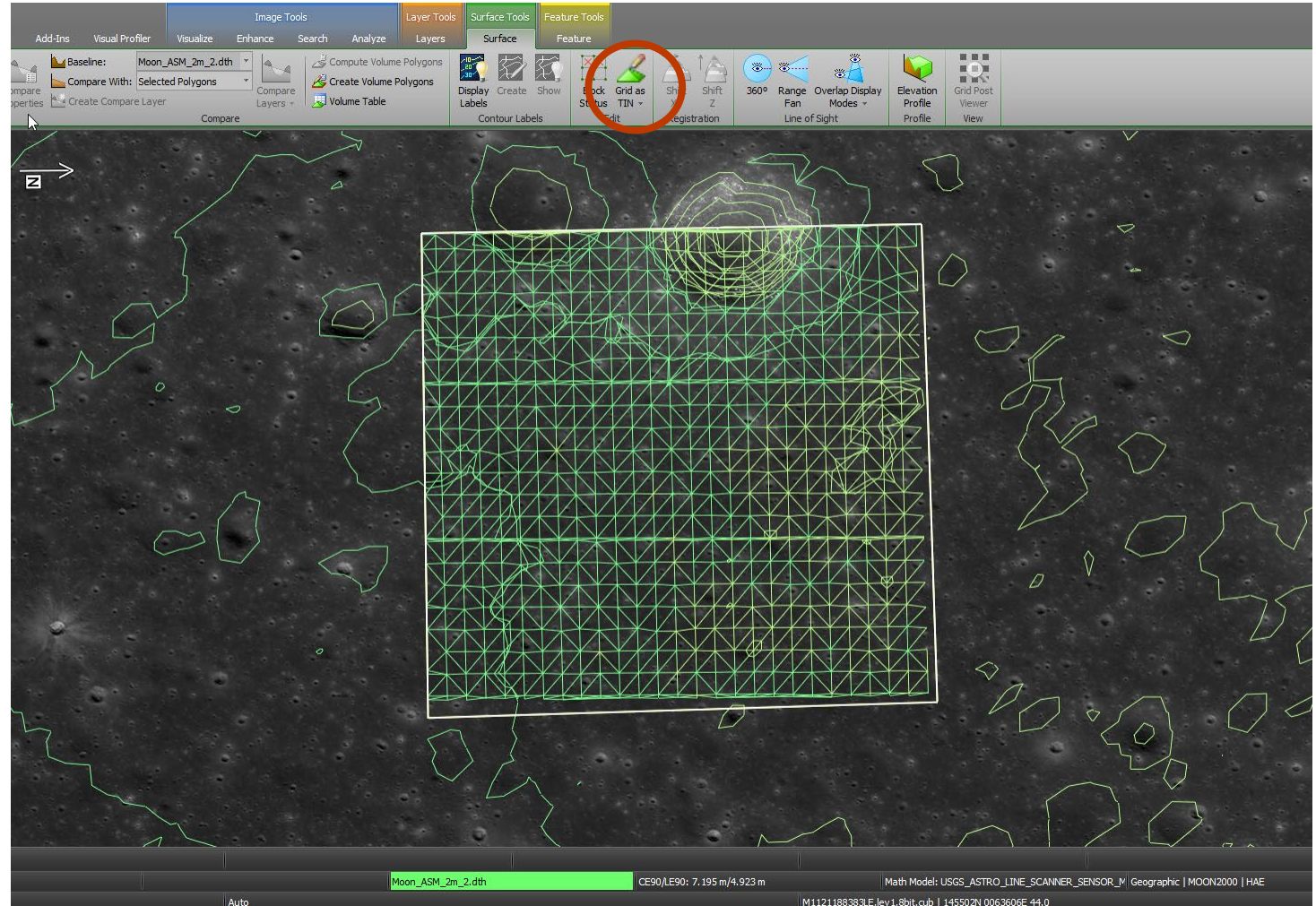



# United States Message Text Format – USMTF Generation

- Create USMTF Messages using information derived from Imagery loaded into a Multiport.
- Transmit USMTF messages via interaction with the Common Message Processor (CMP) and GTCS systems.
- The text message is created using image metadata and interactive graphics to auto-fill the USMTF with as many fields as possible.
- An XML schema template is provided, which can be customized for specific messaging requirements.
- Create a “cheat sheet” when using extracted fields from auto-labels within a USMTF.

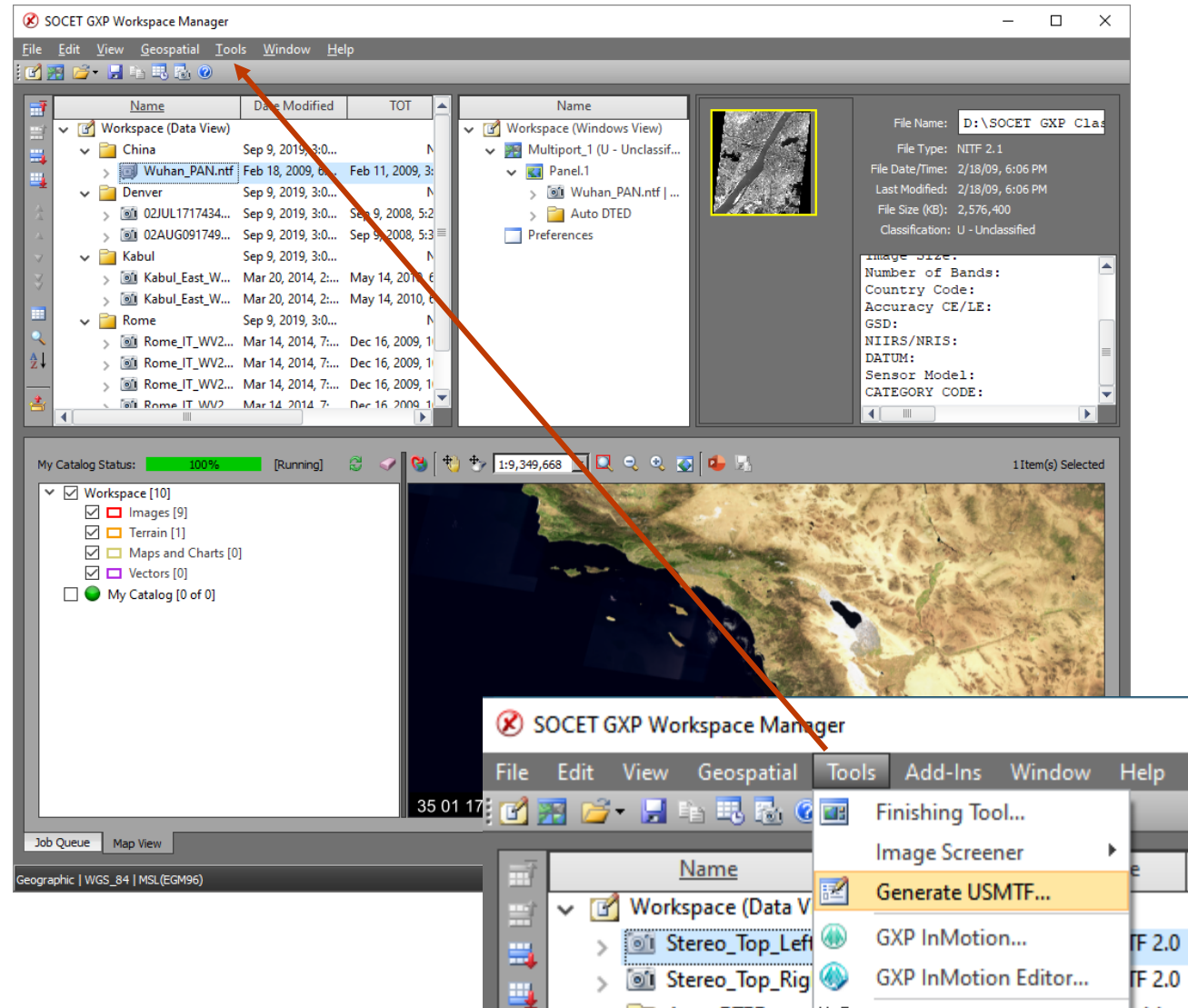

## United States Message Text Format – USMTF Generation ...2

- Create USMTF from a right-click of a point using information from the point and imagery to begin filling out the USMTF message structure.
- Add support for C281 new report type.
- Coordinates, CE, LE, and TLE values are set automatically for USMTF.
- Allow analyst to edit point/target name for the message.
- Include default templates for each message type.
- Make TST / TGTD mandatory entries.

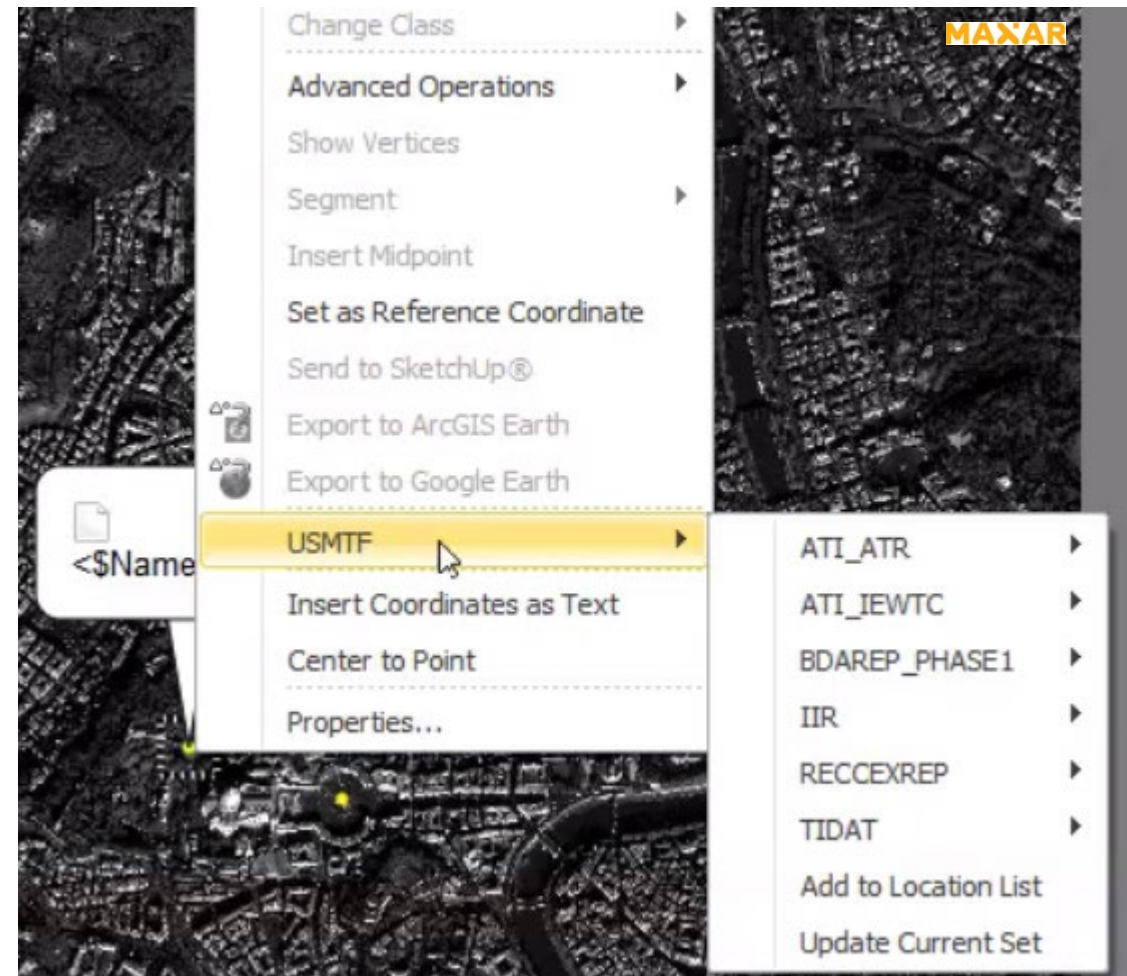

# Modernized Intelligence Database (MIDB) integration

- GXP Xplorer Platform Integration.
  - Data model updates including MIL-STD 2525B symbols.
  - New SOCET GXP Ribbon connection for MIDB.
- Updated layer manager to include content filters based on attribution.
- Switch between MIL-STD 2525B symbols and customer, or simple symbols.

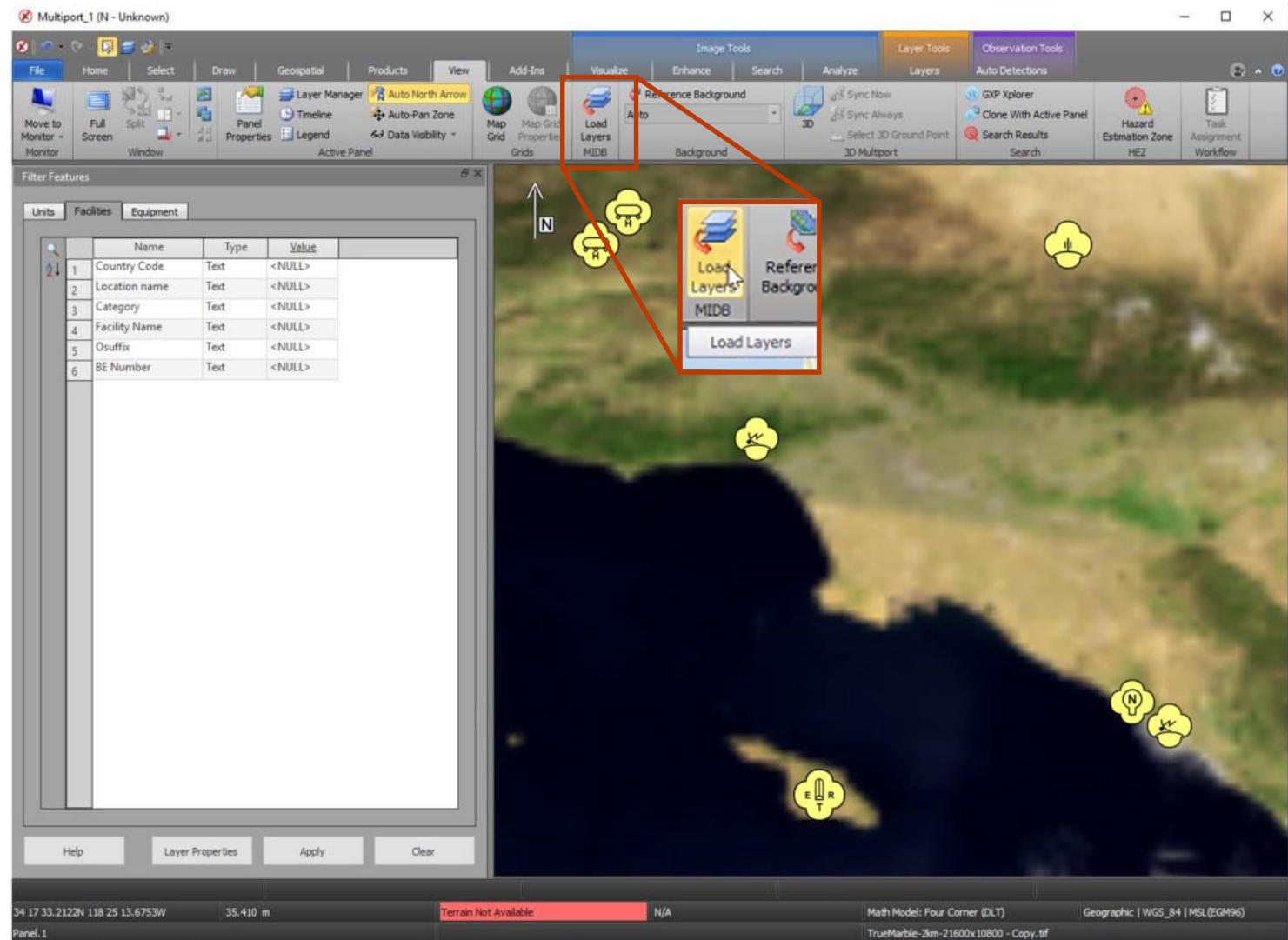

# GXP Automated Tools for Object Recognition (GATOR)

- Software developed under a research and development (R&D) program.
- Productized as a SO CET GXP Job service.
- Identifies objects over a Region of Interest (ROI) based on the selection of a 3-D model.
- Interaction with models allows for translation and rotation of 3D models in 2D Multiports.
- Toggle the display between 2D and 3D models in the 2D Multiport.
- Orientation of the 3D model is an additional attribute for 3D observations.
- SO CET GXP now supports loading GATOR results that were run in the GXP Xplorer Platform.
- Users can submit jobs to the server from the desktop and receive notifications when completed.
- Improved notification support.
- Added .obj support of models.
- Added Image Source Classification to GATOR detections.
  - Each detection now will have an image classification attribute that will be used to identify the classification of the imagery used for the detection workflows.

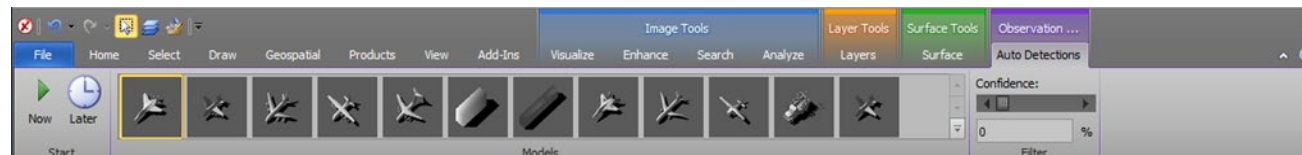

# Transpose Height and Speed for A2A workflow

- Flipped the x, x axis to make it more readable.

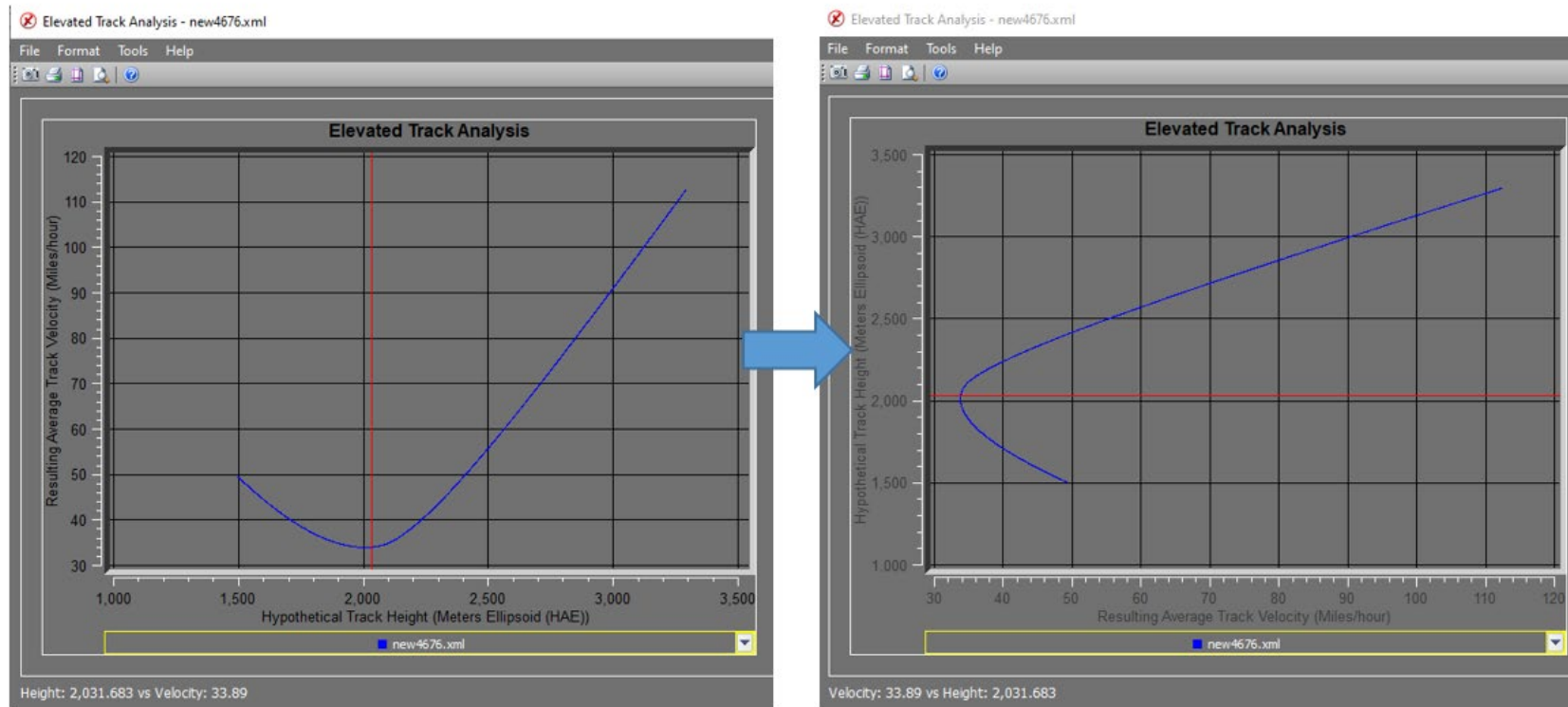

## Other significant enhancements

- Include the ability to set default values for attributes in a GATR file.
- Enhanced Control Image Base (eCIB) production.
  - Code "M" and "X" used for 1m, 5m, 10m products.
  - Modify default eCIB configuration files for Control Handling in the case of unclassified products.
  - Removed defaults for Control Handling in the \$SOCETGXPDIR/Config/internal\_dbs/CIB/ECIB\_default\_comp.mdt file.
- Add a check box column for the GXP Xplorer Servers Status window indicating the primary server.
- Update SIPS to the latest version.
- Updates for Multi-File STANAG 4676B.
  - When loading data, use the Product ID instead of the file system name allowing the name to be consistent across all data for the same collection (for same source).

## Other significant enhancements ...2

- New “best” terrain tracking preference.
  - Prefer cataloged terrain over terrain loaded with imagery.
- Change orientation for ICEYE GeoTIFF with look-side=right.
- Improved metadata support for GeoPDF.
- Fixed support of COSMO-SkyMed HDF5 data.
- Support for connecting to a PostgreSQL database over Secure Sockets Layer (SSL).
- Combined recording preferences to Preferences > Multiport > Video Recording.
- Improved support for Ground Moving Target Indicator (GMTI) metadata.
- Display GMTI sensors and collection areas.
- Increase to supported Web Map Tile Service (WMTS) scales.



Enable Terrain Tracking for 2D Mono Multiports  Prefer Cataloged Terrain

## Other significant enhancements ...3

- Enabled support for high resolution displays by default, no longer required to set environment variable.
- Log into GEOAxis through SOCET GXP and GXP InMotion desktop.
- Load, edit, and save Defense Gridded Elevation Data (DGED).
- Support for loading zipped shapefiles into SOCET GXP and GXP InMotion desktop (including .shz files).
- Support for ArcGIS Pro 3.
- Change transparency for features in the 2D and 3D Multiports.
- Added Map Background tab to quickly switch between up to ten backgrounds.
- Create a new specification file (.spc) from an existing Geodatabase.
- Authenticate directly to ArcGIS Enterprise servers.
- Legends are now available when editing Templates.
- Support for loading g|TF data in the 3D Multiport.



## Other significant enhancements ...4

- Default templates updated to reflect customer workflows.
- Users can now view and edit terrain in a Stereo Multiport without having an image loaded.
- Removed old image sources from Ortho Photo Generation.
- .bmp, .gif and SUN Raster.
- Added additional support for large .ocov files.
- We manage larger files to prevent corrupt data and crashes.
- Removed "Apply Atmospheric Correction" from the Change Sensor model UI.
- We now auto-apply Atmospheric Correction when available.

## Other significant enhancements ...5

- Added RESTful API example to the DevKit for users to reference.
- Added additional job details when a GATOR job is triggered from SOCET GXP.
  - Provides users additional job information.
- Added support for AOI Polygon searches utilizing GATOR.
  - Allows users to specify a location versus running it on the whole image/images loaded in the panel.

## New Pixel Streaming option

- GXP Xplorer can now stream pixels to SOCET GXP using an OGC WMTS protocol with detailed metadata as opposed to the GXP Tile Streamer.
  - Benefits include:
    - SOCET GXP can continue to exploit scenes where communication is interrupted or restarted on the backend.
    - Allows for site caching of imagery tiles for multiple users.
    - Allows for pre-generated tile content with tile pyramid functionality.
      - Allows for streaming to be performed without a running pixel service as tiles are created at ingest as opposed to on user demand.
    - Decreased bandwidth requirements with JPEG 2000 Numerically Lossless compression for WMTS.
  - This can be set in Administration Settings ... GXP Xplorer Application Settings ... Discovery Agent ... Detailed Metadata Processor.
    - This setting only applies to SOCET GXP v4.5.0.1 or later.
    - GXP WebView® will still exclusively use the GXP Tile Streamer.

## New Pixel Streaming option ...2

- A new set of options has been added to the Administration Settings to allow for pre-generating tiles to be used for the new WMTS protocol.
  - If this data is generated, no active pixel streaming needs to occur at demand time.
  - Administration Settings ... GXP Xplorer Application Settings ... Discovery Agent ... Tile Pyramid Ingest Processor
  - Requires On File Discovery RSet mode.
  - Open in SO CET GXP requires CRS-1 (image space) coordinate system.

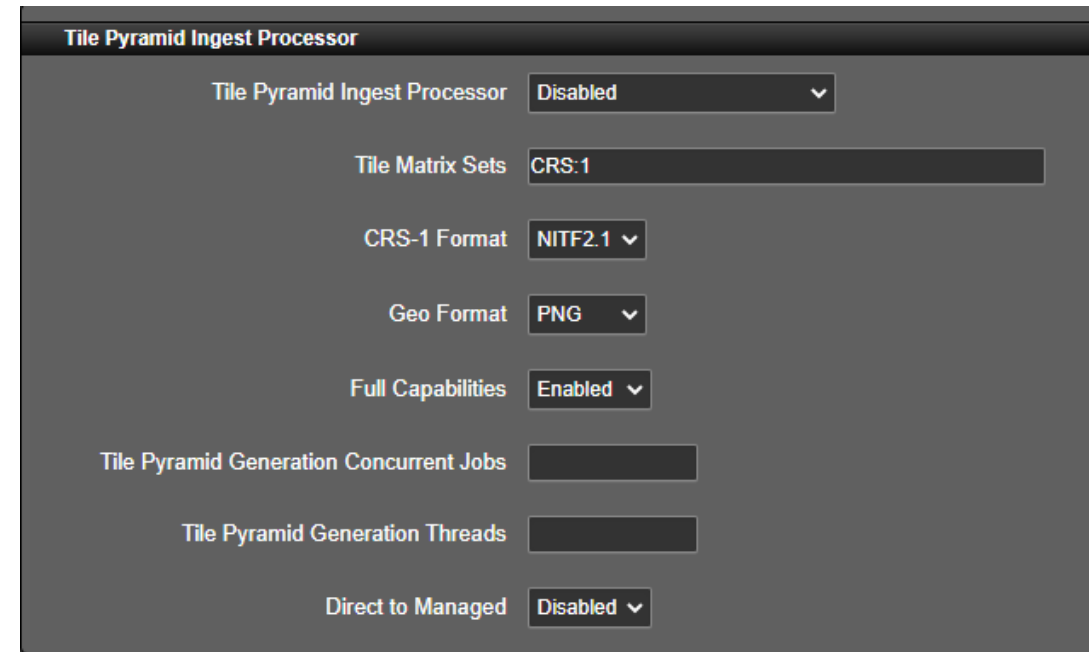

The screenshot displays the configuration interface for the 'Tile Pyramid Ingest Processor'. The settings are as follows:

| Setting                                 | Value    |
|---|----------|
| Tile Pyramid Ingest Processor           | Disabled |
| Tile Matrix Sets                        | CRS:1    |
| CRS-1 Format                            | NITF2.1  |
| Geo Format                              | PNG      |
| Full Capabilities                       | Enabled  |
| Tile Pyramid Generation Concurrent Jobs |          |
| Tile Pyramid Generation Threads         |          |
| Direct to Managed                       | Disabled |

# Increased default performance preferences

- Meeting the needs of more performant hardware out of the box.

## Performance Preference location

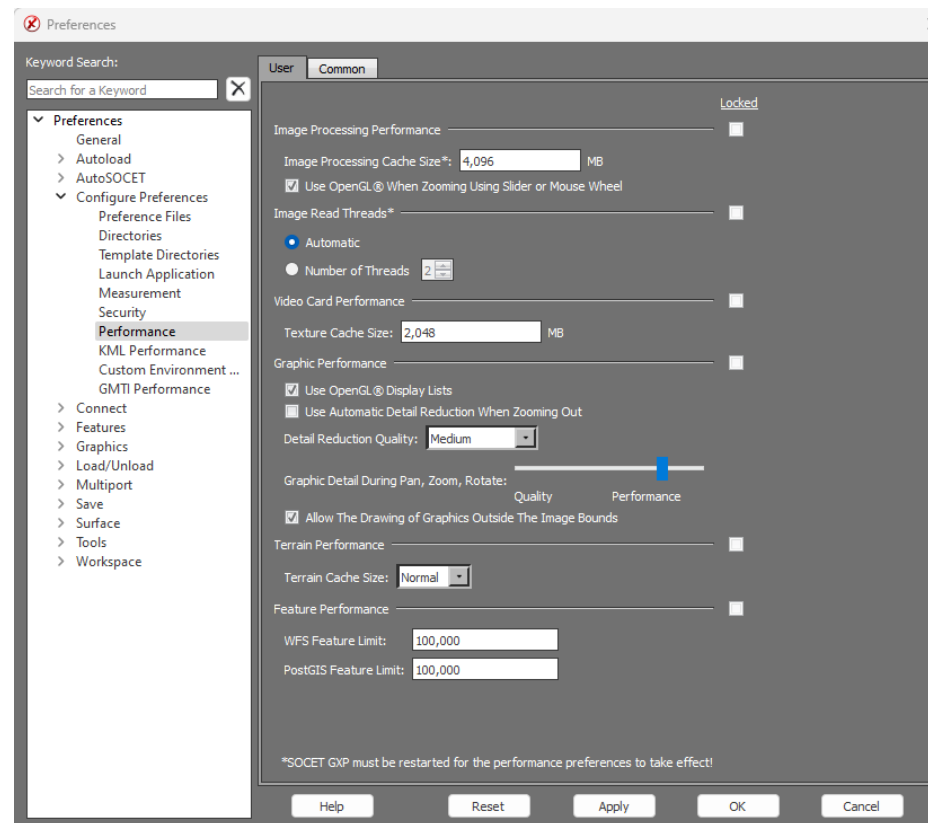

# Increased GXP Job Service performance

- Meeting the needs of more performant hardware out of the box.

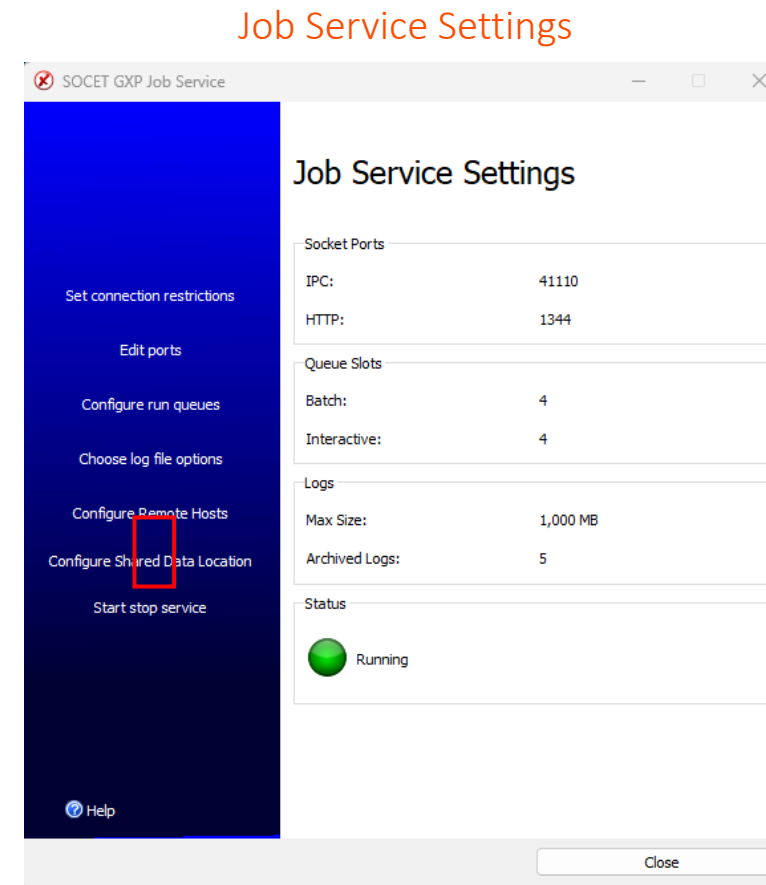

# New GeoPackage Preference

- Users can now check a preference to use AutoDTEd for GeoPackage data to align it better to their data.



## GeoPackage Preference location

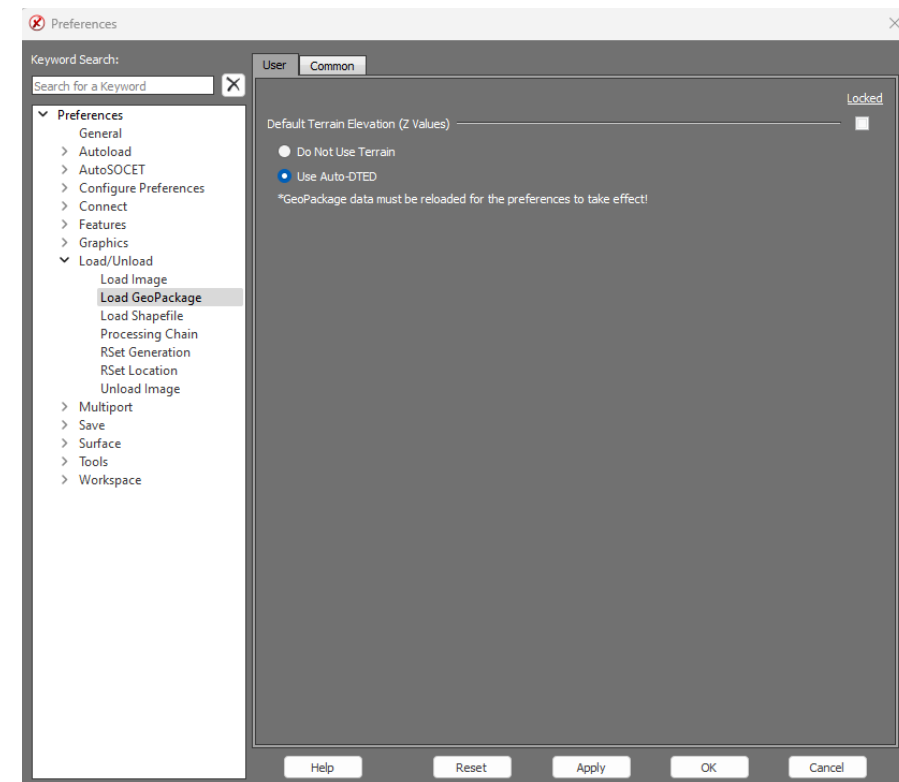

# New GeoPackage Preference ...2

Before

After

|   | Coordinates                    | Elevation | Height Above Terrain |
|---|--------------------------------|-----------|----------------------|
| 1 | 41 54 24.4719N 012 27 17.0740E | 0.000 m   | -51.987 m            |
| 2 | 41 54 24.2360N 012 27 17.0209E | 0.000 m   | -54.182 m            |
| 3 | 41 54 24.0561N 012 27 18.0659E | 0.000 m   | -54.001 m            |
| 4 | 41 54 24.1504N 012 27 18.0962E | 0.000 m   | -52.951 m            |
| 5 | 41 54 24.1113N 012 27 18.3566E | 0.000 m   | -51.379 m            |
| 6 | 41 54 23.7999N 012 27 18.3815E | 0.000 m   | -51.534 m            |
| 7 | 41 54 23.8630N 012 27 18.7997E | 0.000 m   | -48.543 m            |
| 8 | 41 54 23.4041N 012 27 18.8341E | 0.000 m   | -47.204 m            |
| 9 | 41 54 23.4141N 012 27 18.3938E | 0.000 m   | -50.402 m            |

Average selected Height Above Terrain: -49.121 m  
Average selected Elevation: 0.000 m

|   | Coordinates                    | Elevation | Height Above Terrain |
|---|--------------------------------|-----------|----------------------|
| 1 | 41 54 09.6765N 012 27 13.5467E | 61.975 m  | 0.000 m              |
| 2 | 41 54 09.5571N 012 27 13.6562E | 62.734 m  | 0.000 m              |
| 3 | 41 54 09.6068N 012 27 14.4908E | 62.124 m  | 0.000 m              |
| 4 | 41 54 09.4535N 012 27 14.5325E | 63.132 m  | 0.000 m              |
| 5 | 41 54 09.4472N 012 27 15.5082E | 60.449 m  | 0.000 m              |
| 6 | 41 54 09.1518N 012 27 15.5724E | 61.737 m  | 0.000 m              |
| 7 | 41 54 09.1091N 012 27 17.2642E | 52.209 m  | 0.000 m              |
| 8 | 41 54 09.7463N 012 27 17.2190E | 51.207 m  | 0.000 m              |
| 9 | 41 54 09.7414N 012 27 18.0588E | 47.600 m  | 0.000 m              |

Average selected Height Above Terrain: 0.000 m  
Average selected Elevation: 55.146 m



# Access GXP Xplorer Forms from SOCET GXP

- Users can access Forms hosted in GXP Xplorer Platform.
- Forms are loaded directly into the Workflow System View.
- Completed forms can be reviewed in a web browser.

The screenshot displays the GXP Xplorer Platform interface. On the left, a 'Task Queue' table lists tasks with columns for Job ID, Task Name, Description, and Date Created. The task with Job ID (7737) is highlighted. The main area shows the 'Task Steps' for this task, including 'Aircraft Type' (Boeing 777), 'Aircraft Count' (13), and 'Date Collected' (2023-12-25 15:16:21). A 'Work Packet' sidebar on the right shows a tree view with folders for 'Source Data', 'Products', and 'Pending Uploads'. At the bottom, there are 'SAVE' and 'MARK COMPLETE' buttons. The interface also includes a 'Task Queue' dropdown, a 'Retrieve Tasks' button, and a 'Display:' dropdown menu.

| Job ID | Task Name | Description | Date Created            |
|--------|-----------|-------------|-------------------------|
| (8102) | Comple... |             | Mar 6, 2024, 3:14:31 PM |
| (8023) | Comple... |             | Mar 6, 2024, 3:14:26 PM |
| (7949) | Comple... |             | Mar 6, 2024, 3:14:20 PM |
| (7877) | Comple... |             | Mar 6, 2024, 3:14:15 PM |
| (7807) | Comple... |             | Mar 6, 2024, 3:14:10 PM |
| (7737) | Comple... |             | Mar 6, 2024, 3:14:05 PM |
| (7665) | Comple... |             | Mar 6, 2024, 3:14:00 PM |
| (7593) | Comple... |             | Mar 6, 2024, 3:13:55 PM |
| (7523) | Comple... |             | Mar 6, 2024, 3:13:50 PM |
| (7451) | Comple... |             | Mar 6, 2024, 3:13:45 PM |
| (7349) | Comple... |             | Mar 6, 2024, 3:13:40 PM |
| (7277) | Comple... |             | Mar 6, 2024, 3:13:35 PM |
| (7169) | Comple... |             | Mar 6, 2024, 3:13:29 PM |
| (7061) | Comple... |             | Mar 6, 2024, 3:13:24 PM |
| (6979) | Comple... |             | Mar 6, 2024, 3:13:19 PM |
| (6897) | Comple... |             | Mar 6, 2024, 3:13:14 PM |
| (6815) | Comple... |             | Mar 6, 2024, 3:13:09 PM |
| (6707) | Comple... |             | Mar 6, 2024, 3:13:04 PM |

# Added Autoload DTED based on image footprints preference

- Improves performance when loading large amounts of data associated with an image.

## Autoload Terrain based on image footprints Preference location

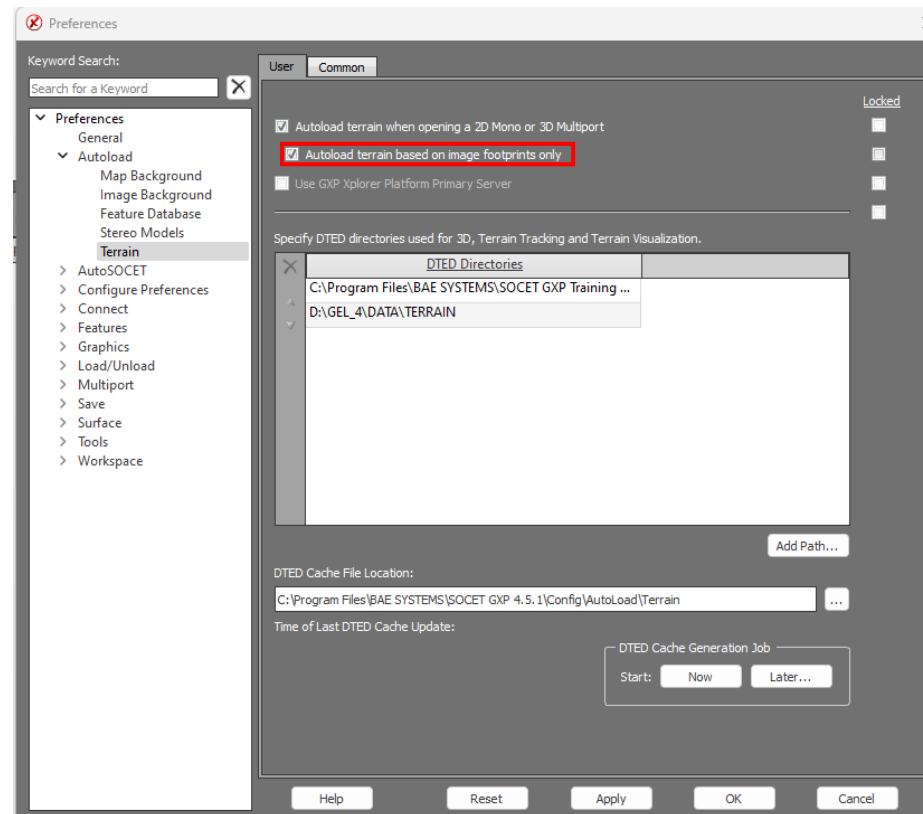

# Added Autoload DTED based on image Footprints preference ...2

Before

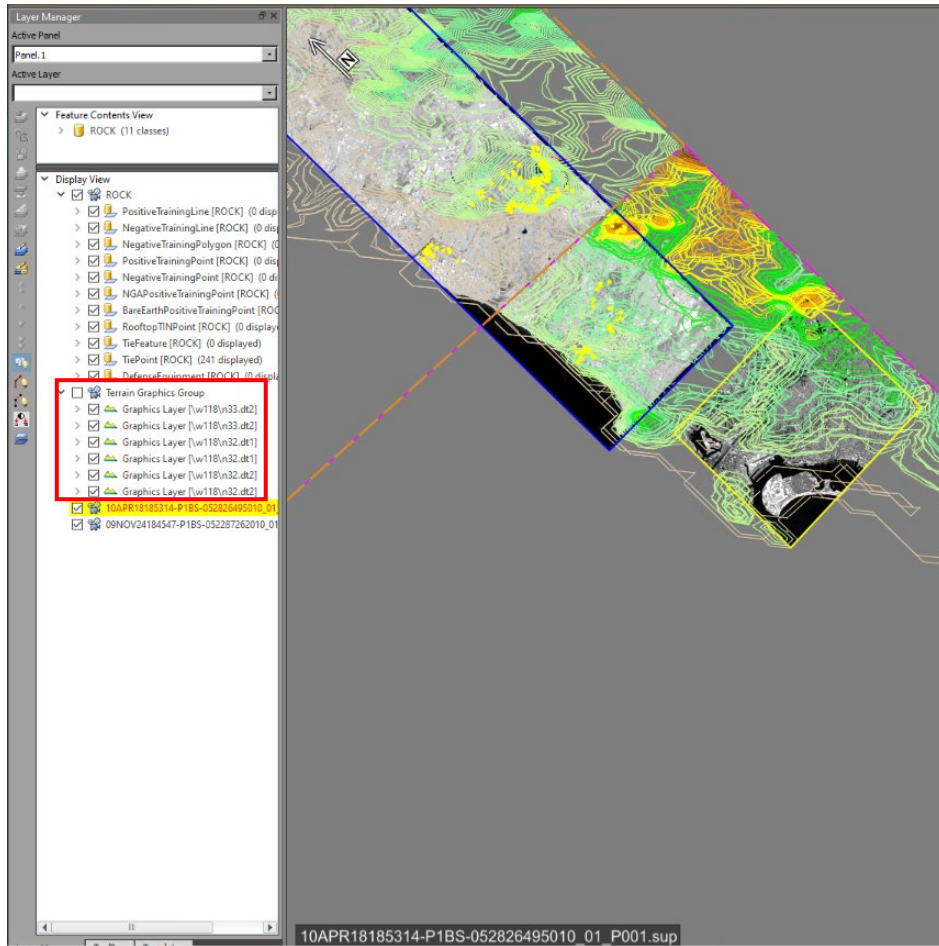

After

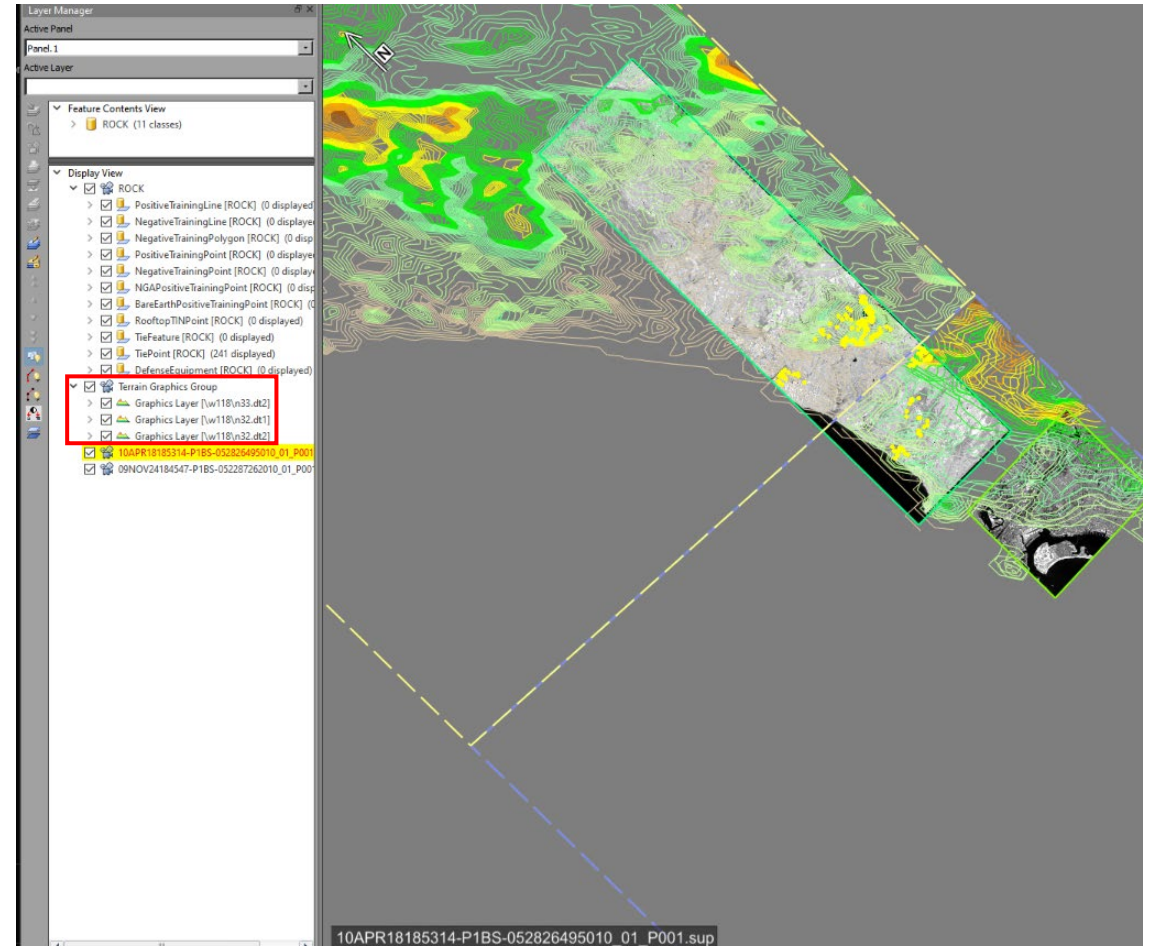

© 2024 Maxar Technologies.

# GXP Xplorer Connector Reference Data

- Use Reference data for additional situational awareness using the GXP Xplorer Search tool.

## GXP Xplorer Reference Map Background Preference Location

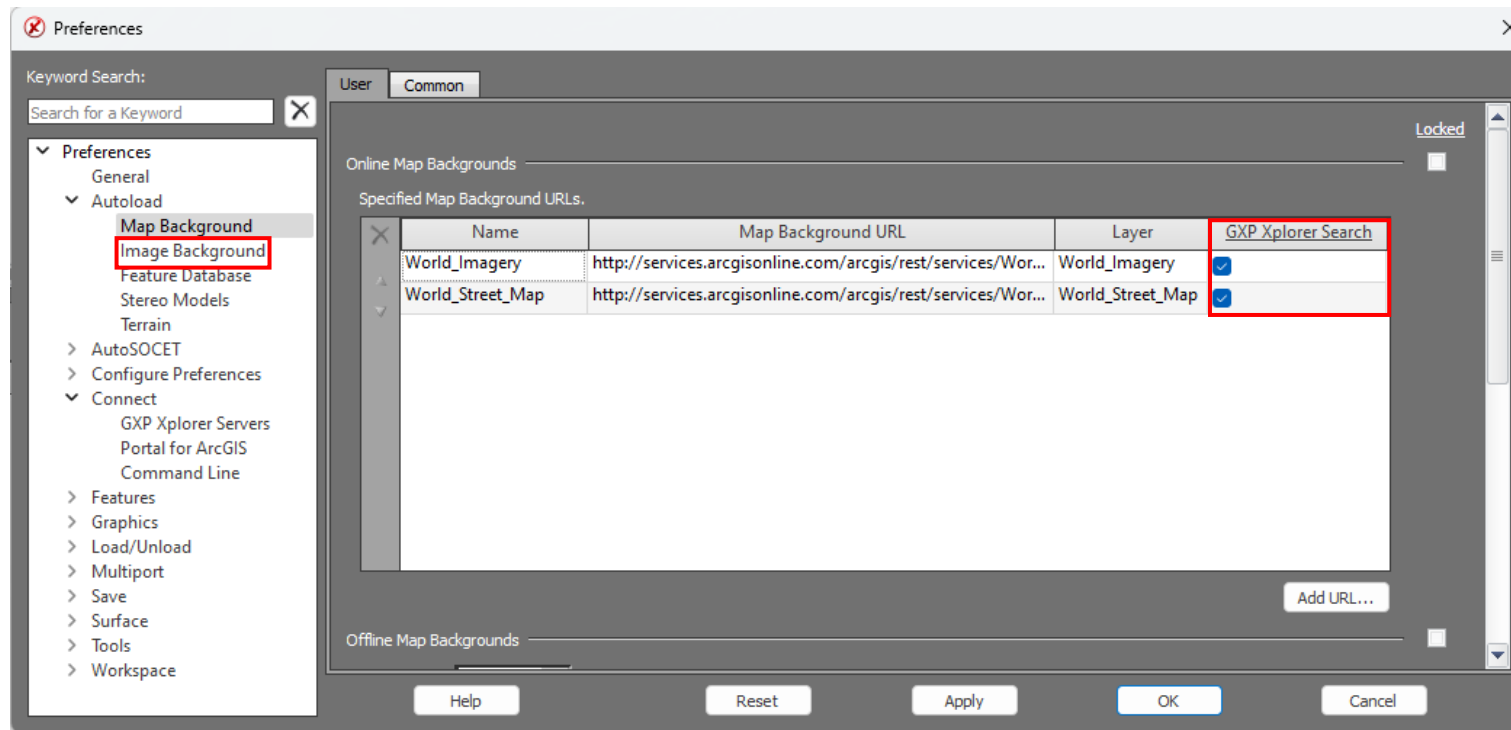

# GXP Xplorer Connector Reference Data ...2

Source Image

The screenshot displays the GXP Xplorer Connector interface. At the top, two preview windows show satellite imagery of a coastal area. The left window is labeled 'Preview Mode (Source Image Background)' and has a yellow border. The right window has a red border and shows a red bounding box around a specific area of the image. Below the preview windows is a search results table with the following data:

| Date Collected          | Filename                 | Tags (Type)                 | Sensor Name (Derived) | Size               | Files/Number o | Downloadable/Status |
|-------------------------|--------------------------|-----------------------------|-----------------------|--------------------|----------------|---------------------|
| No filter selected      | No filter selected       | No filter selected          | No filter selected    | No filter selected |                |                     |
| Jan 1, 2010, 6:52:16 PM | 10JAN01185216-P1BS_R1... | Image NITF NITF2.1 VIS V... | WV02                  | 478,402,597 bytes  | Yes / Unknown  | Yes                 |
| Jan 1, 2010, 6:52:16 PM | 10JAN01185216-P1BS_R1... | Image NITF NITF2.1 VIS      | WV02                  | 478,402,597 bytes  | Yes / Unknown  | No                  |
| Nov 2, 2009, 6:39:58 PM | 09NOV02183956-P1BS-05... | Image NITF NITF2.1 VIS V... | WV02                  | 361,807,012 bytes  | Yes / Unknown  | Yes                 |
| Nov 2, 2009, 6:39:58 PM | 09NOV02183956-P1BS-05... | Image NITF NITF2.1 VIS      | WV02                  | 361,807,012 bytes  | Yes / Unknown  | No                  |
| Feb 9, 2008, 6:31:40 PM | 08FEB09183209-P1BS_R4... | Image NITF NITF2.1 VIS V... | WV01                  | 448,504,027 bytes  | Yes / Unknown  | Unknown             |
| Feb 9, 2008, 6:31:40 PM | 08FEB09183209-P1BS_R4... | Image NITF NITF2.1 VIS      | WV01                  | 448,504,027 bytes  | Yes / Unknown  | Unknown             |

Below the table, there is a small thumbnail image and a file path: 09NOV02183956-P1BS-0525654-11/2/09, 6:39 PM. The interface also shows 'Search Results' and 'Returned 6 results'.

© 2024 Maxar Technologies.

# GXP Xplorer Connector Reference Data ...3

## Map Background

The screenshot displays the GXP Xplorer interface. The top half shows a map background with a red bounding box highlighting a specific area. The bottom half shows a search results table with the following data:

| Date Collected          | Filename                 | Tags (Type)                 | Sensor Name (Derived) | Size               | Files/Number o | Downloadable/Status |
|-------------------------|--------------------------|-----------------------------|-----------------------|--------------------|----------------|---------------------|
| No filter selected      | No filter selected       | No filter selected          | No filter selected    | No filter selected |                |                     |
| Jan 1, 2010, 6:52:16 PM | 10JAN01185216-P1BS_R1... | Image NITF NITF2.1 VIS V... | WV02                  | 478,402,597 bytes  | Yes / Unknown  | Yes                 |
| Jan 1, 2010, 6:52:16 PM | 10JAN01185216-P1BS_R1... | Image NITF NITF2.1 VIS      | WV02                  | 478,402,597 bytes  | Yes / Unknown  | No                  |
| Nov 2, 2009, 6:39:58 PM | 09NOV02183956-P1BS-05... | Image NITF NITF2.1 VIS V... | WV02                  | 361,807,012 bytes  | Yes / Unknown  | Yes                 |
| Nov 2, 2009, 6:39:58 PM | 09NOV02183956-P1BS-05... | Image NITF NITF2.1 VIS      | WV02                  | 361,807,012 bytes  | Yes / Unknown  | No                  |
| Feb 9, 2008, 6:31:40 PM | 08FEB09183209-P1BS_R4... | Image NITF NITF2.1 VIS V... | WV01                  | 448,504,027 bytes  | Yes / Unknown  | Yes                 |
| Feb 9, 2008, 6:31:40 PM | 08FEB09183209-P1BS_R4... | Image NITF NITF2.1 VIS      | WV01                  | 448,504,027 bytes  | Yes / Unknown  | Unknown             |

Returned 6 results

© 2024 Maxar Technologies.

# Non-Earth Registration (NER)

- Intended for Long Range Photogrammetry for images without a sensor model.
- Enables the creation of a sensor model.
  - Enables precise mensuration.
  - Enables 3D modeling.

## NER button location

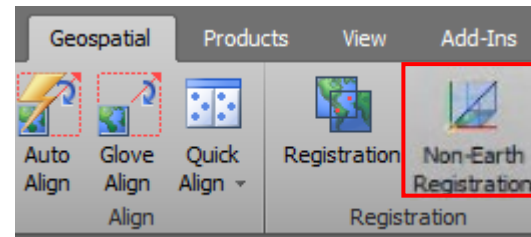

## Non-Earth Registration ...2

- Non-Earth Registration Window.
  - Set sensor parameters.
  - Set sensor metadata information.
  - Access draw tools.
  - Cue Card.
  - Solve.
  - Generate Support File.

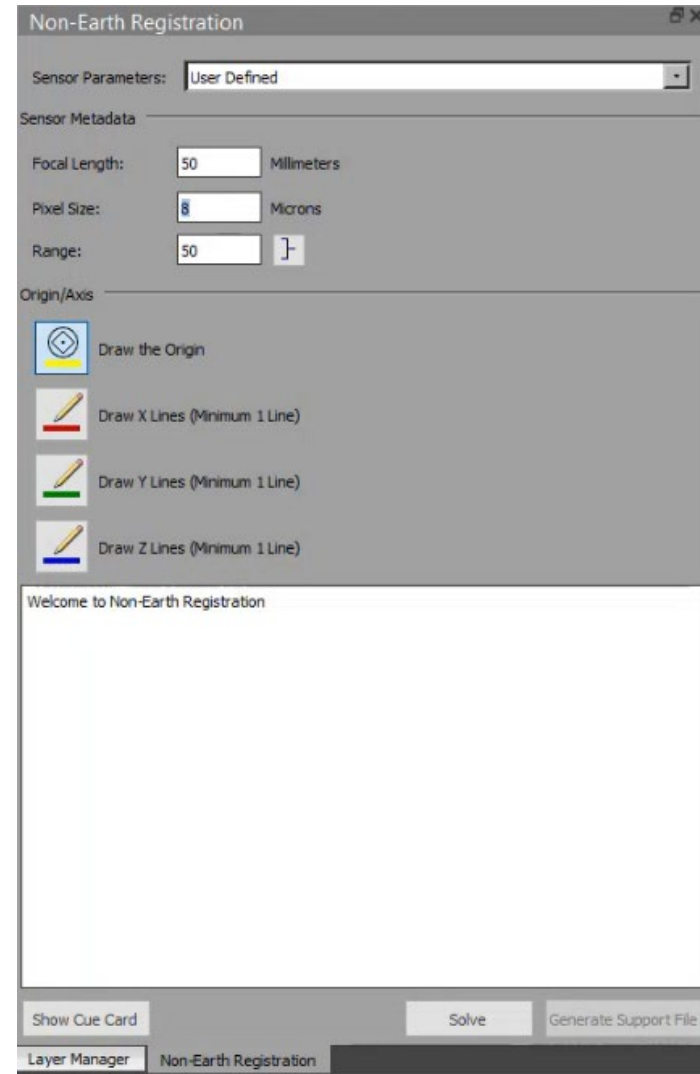



## Non-Earth Registration ...3

- Cue Card Diagram.
  - Provide guidance for utilizing the NER tool.

**Non-Earth Registration Cue Card Diagram**

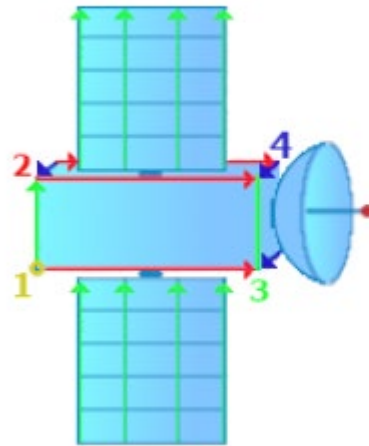

# GXP InMotion v4.5.1.x release enhancements



## GXP InMotion v4.5.1 release enhancements

- This presentation contains the enhancements included in GXP InMotion **v4.5.1.5**.
  - Released September 10<sup>th</sup>, 2024\*.
  - GXP InMotion v4.5.1.5 is patch 12 of the GXP InMotion v4.5.0.0.272 release build. Because all GXP InMotion patches are full installations, users have two options:
    - Upgrade an existing GXP InMotion installation by installing this patch, or...
    - For brand new installations, install this patch for a full installation that includes both the patch and the v4.5.0.0.272 base installation.

*\* Items in teal indicate new features included in the v4.5.1.5 update*

## Live Rewind in one panel

- When Live Rewind was introduced, it was developed with a specific customer in mind; The initial implementation focused on that customer's CONOP of having a real-time instance of the video next to a forensic instance of the same mission.
- In v4.4.1.2 we've expanded Live Rewind's flexibility to allow for side-by-side panels of 'Live' and 'Rewind'.
- In **v4.5.0.0**, Live Rewind able to function all within one panel of one GXP InMotion instance.

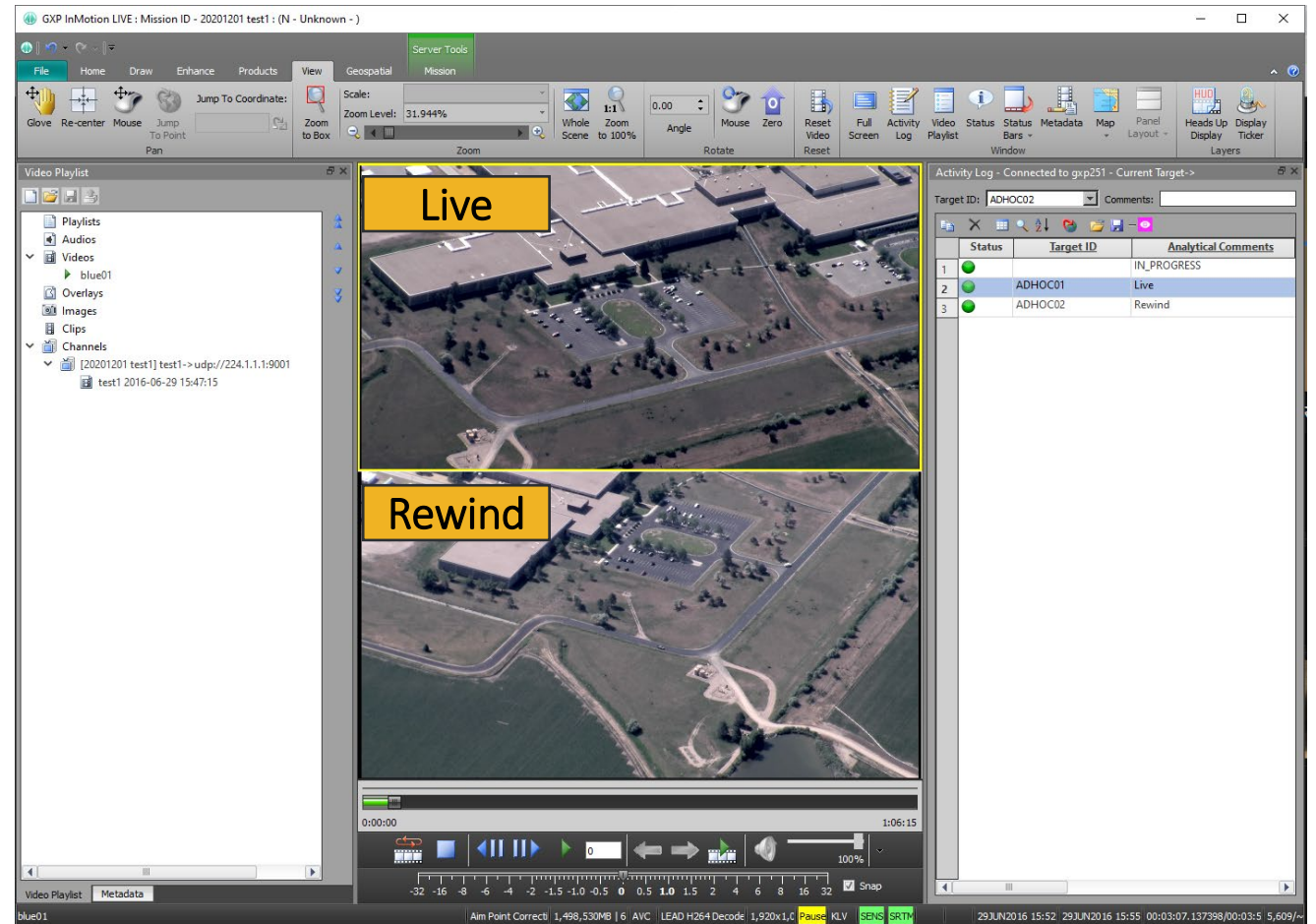

Imagery of MX-15 videos over Ft. Collins, CO; Courtesy of L-3 Communications, EO/IR Inc.

# Esri Advanced GEOINT Systems (AGS) Map/Imagery/Feature support

- Added the ability to display any layer of an Esri MapServer, ImageryServer, and FeatureServer in the GXP InMotion Map window.
- Added the ability to display multiple OGC layers in Map Window.
  - For example, the image to the right is displaying a MapServer layer as the base image, and on top of the imagery are two feature server layers (overlays).
- [https://services.arcgisonline.com/arcgis/rest/services/World\\_Imagery/MapServer](https://services.arcgisonline.com/arcgis/rest/services/World_Imagery/MapServer)
- <https://sampleserver6.arcgisonline.com/arcgis/rest/services/Military/FeatureServer>

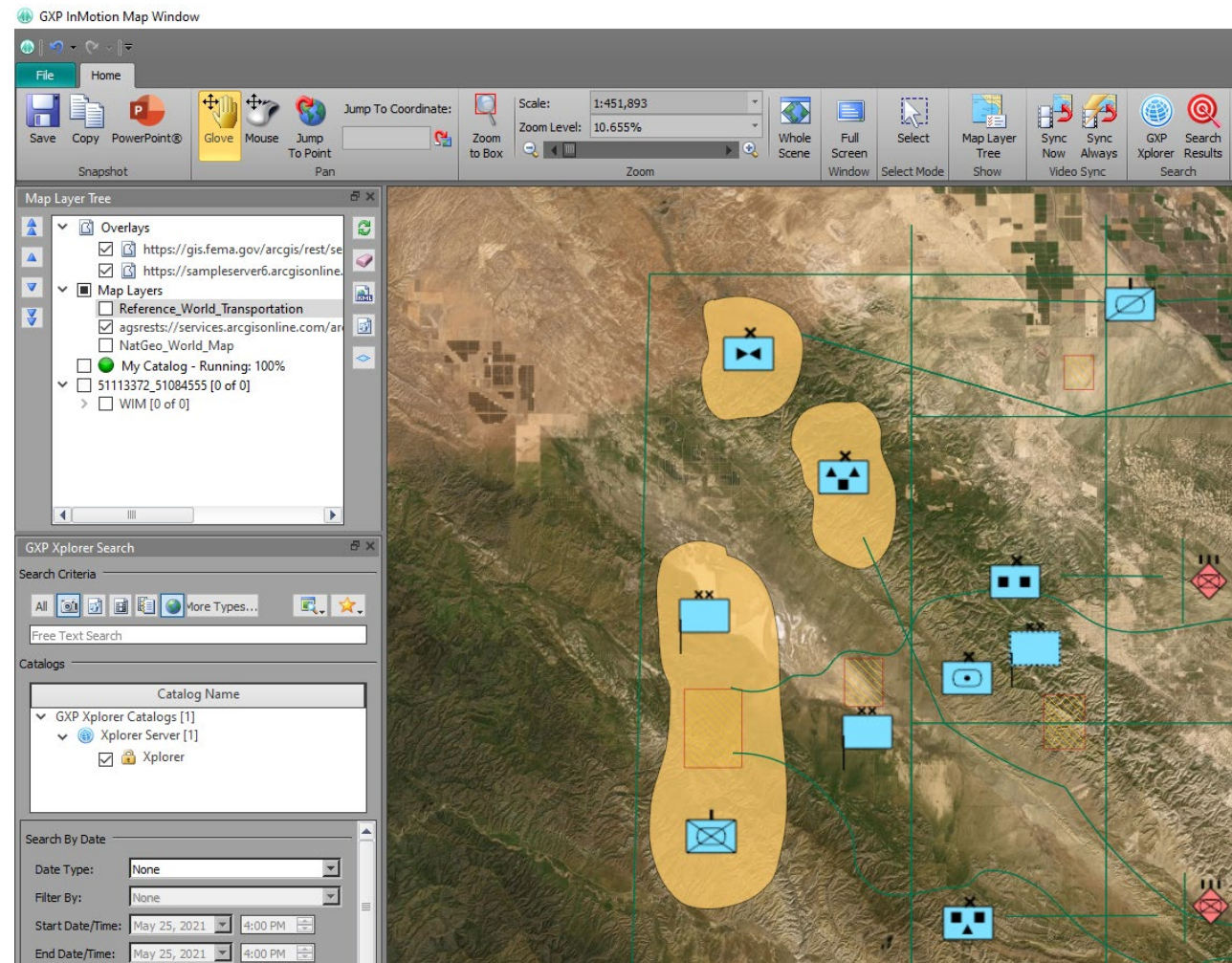

# New Heads Up Display (HUD) editing capabilities

- Ability to reposition and edit HUD elements while video is playing.
- Ability to edit the HUD across all six multi-panels.

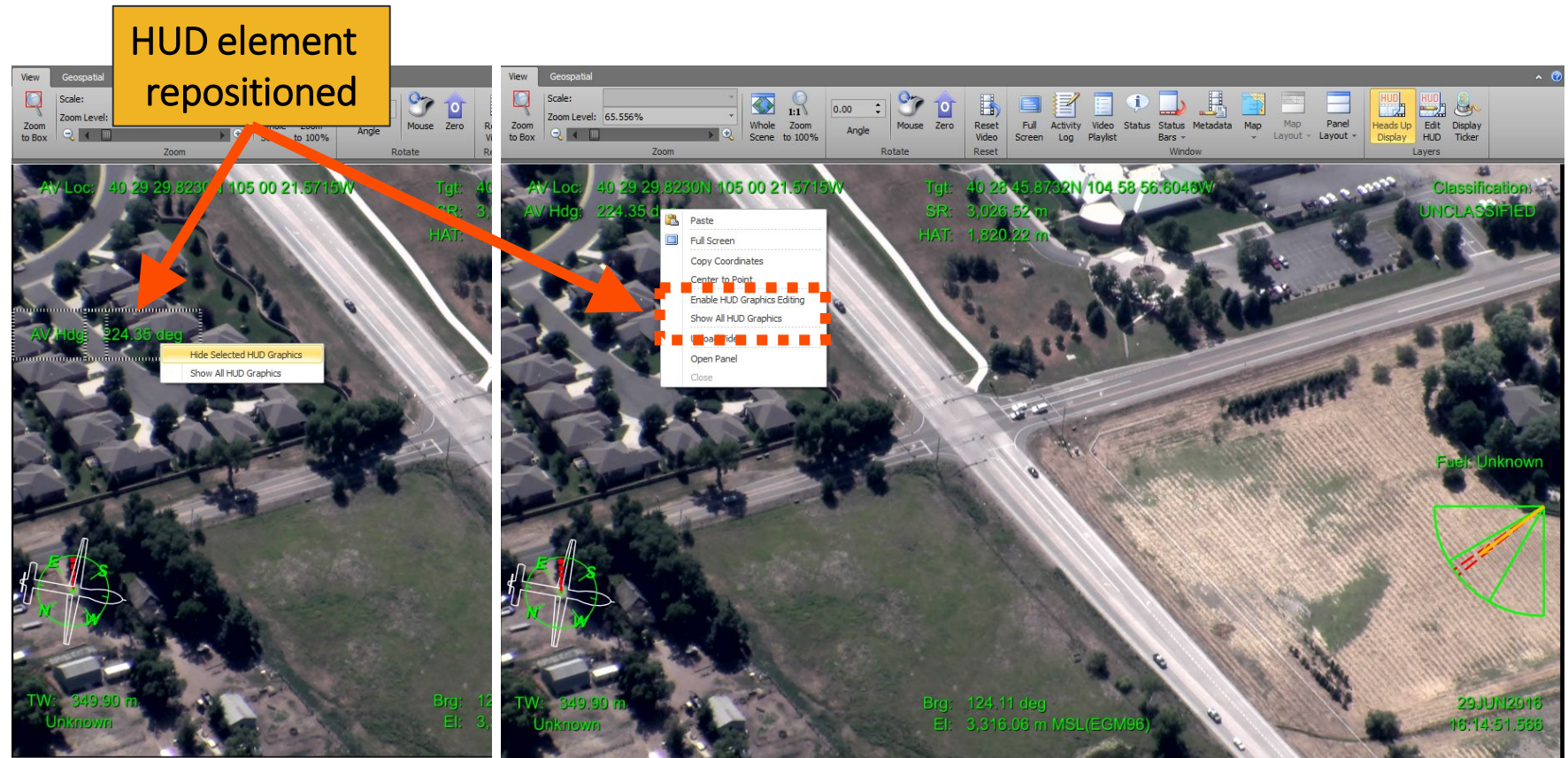

Imagery of MX-15 videos over Ft. Collins, CO; Courtesy of L-3 Communications, EO/IR Inc.

# Integration of GXP InMotion with Esri ArcGIS Earth

- Interface with ArcGIS Earth using a simple button interface from the GXP InMotion Home tab.
  - Center Map in ArcGIS Earth.
  - Draw Footprint in ArcGIS Earth.
  - Draw Air Vehicle in ArcGIS Earth.

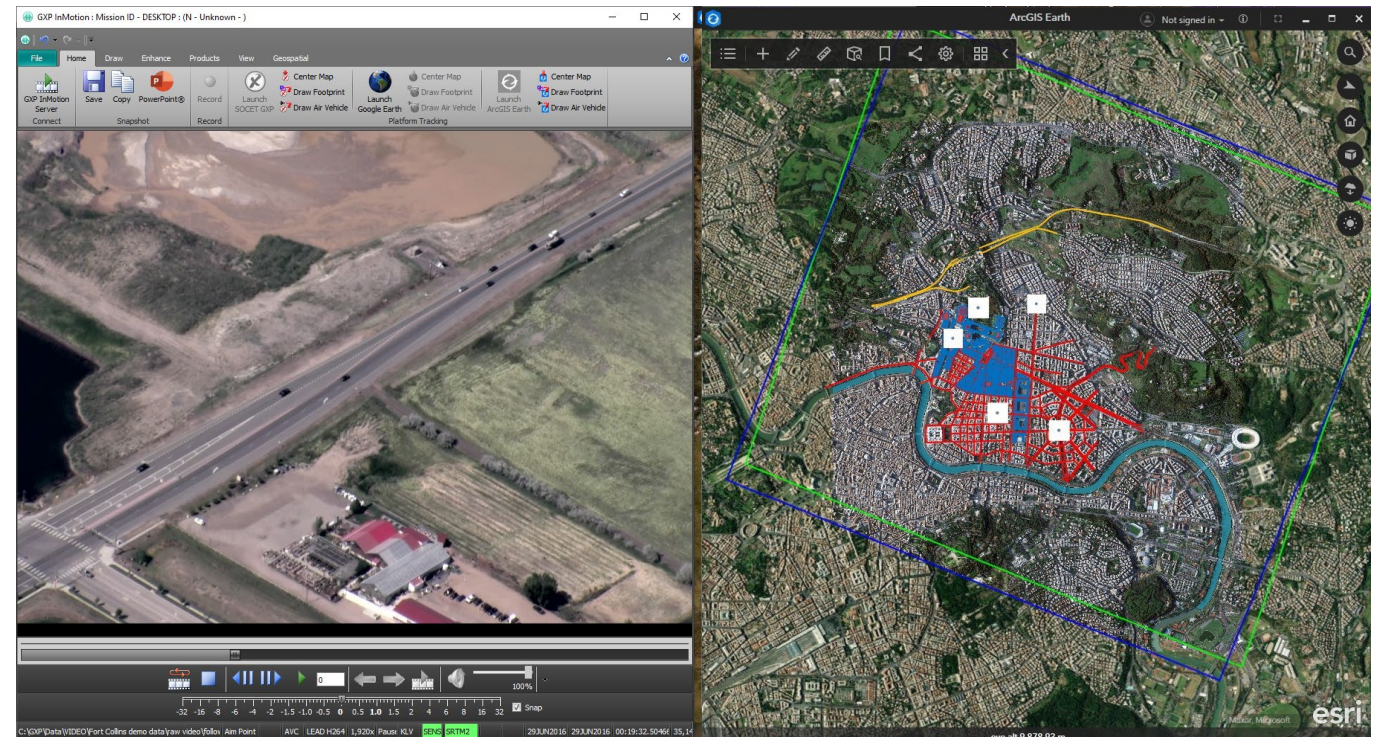

Imagery of MX-15 videos over Ft. Collins, CO; Courtesy of L-3 Communications, EO/IR Inc.

Image © 2022 Maxar Technologies.

## New supported vector format features

- New feature and graphics performance constraints were added to GXP InMotion to better manage feature rendering during video exploitation.
- The GXP InMotion video scene now supports the following vector formats:
  - MIE4NITF embedded shapefiles.
  - GeoJSON files.
  - 4676B (XML) files.
- Added support for live (or network or dynamic) KML overlays.
- Added support for displaying the embedded icons in a KML/ Keyhole Markup language Zipped (KMZ).



# Live KML support for all geometries

- GXP InMotion now supports all geometries contained within KML vector files.
- Typical geometries includes points, polylines, and polygons.
- GXP InMotion now is able to present graphics that are display oriented; for example, embedded map legends.

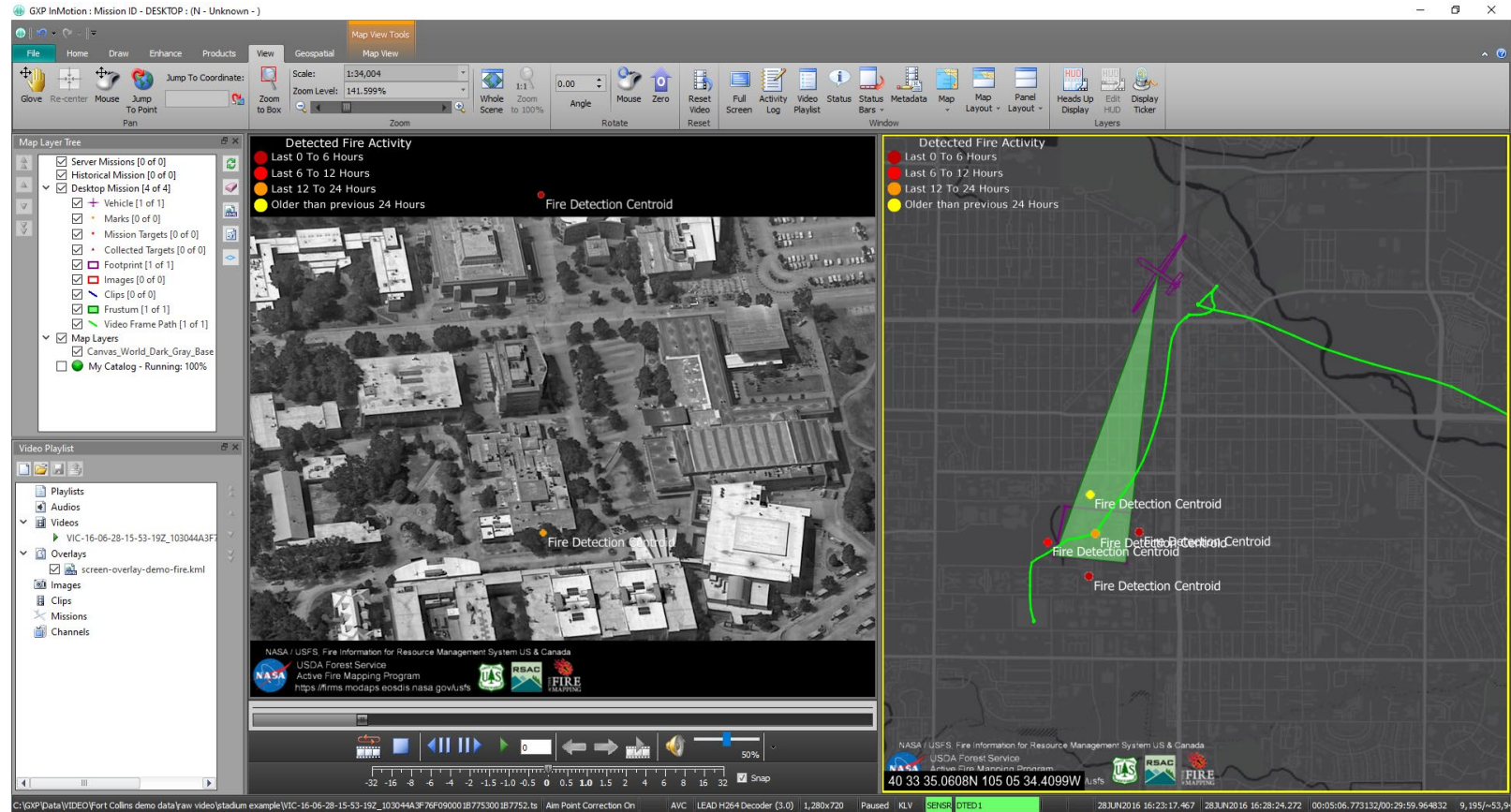

Imagery of MX-15 videos over Ft. Collins, CO; Courtesy of L-3 Communications, EO/IR Inc.

## New supported encoding features

- *“Video encoding converts a given video input into a digital format that is compatible with most types of Web players and mobile devices. In the most basic sense of the term, video encoding is compressing video files so that they are not saved as individual images but as fluid video.”*
- GXP InMotion supports converting H264 (TS) video data with metadata out to MP4, WMV, and Audio Video Interleave (AVI) files. Previously this process only converted the original video and did not include any graphics overlays a user might have overlain during exploitation. GXP InMotion v4.5.0.0 added support for embedding (or burning in) both KML and shapefile vector formats into the resultant video product.

## Embed video into PowerPoint from GXP InMotion

- Currently, after video clips are created, a user can send clips:
  - To a new GXP InMotion instance,
  - The GXP InMotion Editor,
  - Or upload to GXP Xplorer.
- Users now have the ability to send a video clip from the Video Playlist directly to a PowerPoint slide.

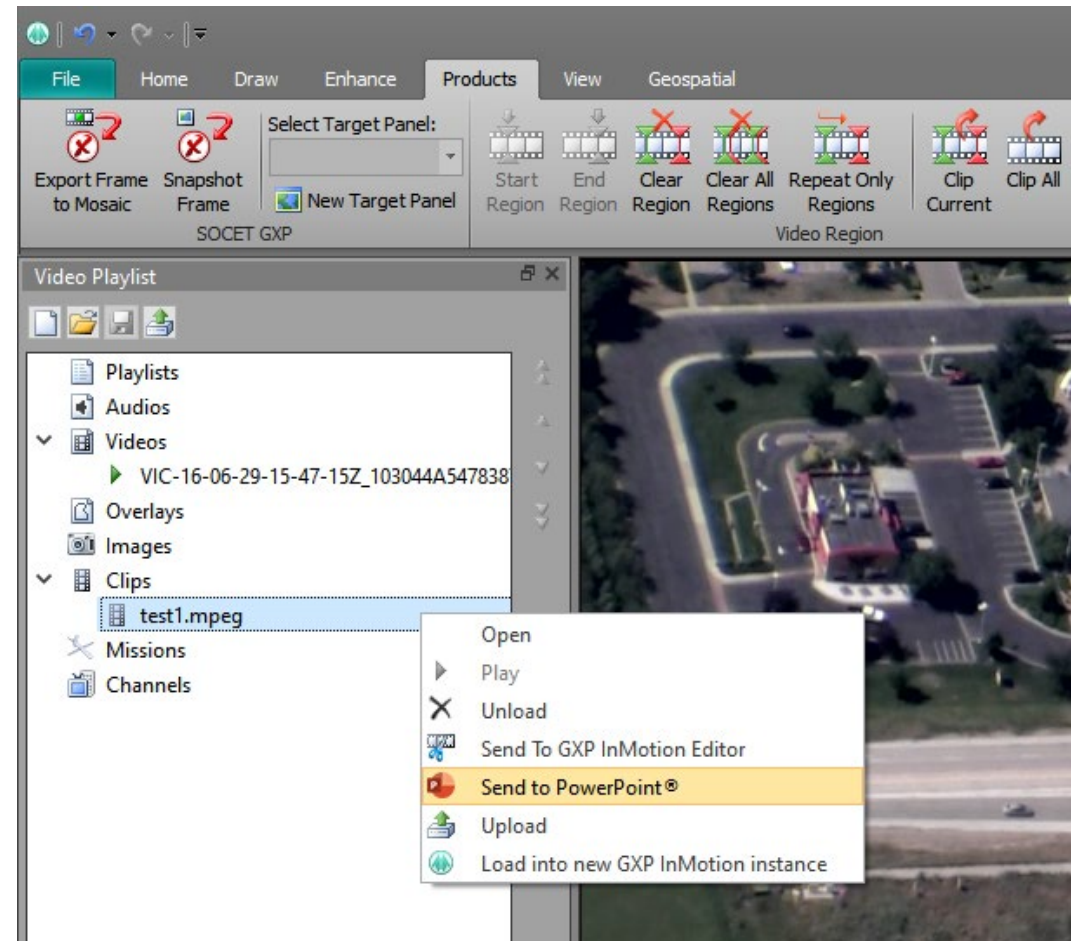

Imagery of MX-15 videos over Ft. Collins, CO; Courtesy of L-3 Communications, EO/IR Inc.

## Allow vectors to be loaded onto Map Window or another panel

- Vector data support has been updated to allow a user to 'push' a previously loaded vector file on the video scene into either another video panel or into the Map Window.
- This enhancement eliminates multiple steps to reload common vector data into multiple locations.
- Vectors supported includes shapefiles, KML/KMZ, and GXP Graphics files.

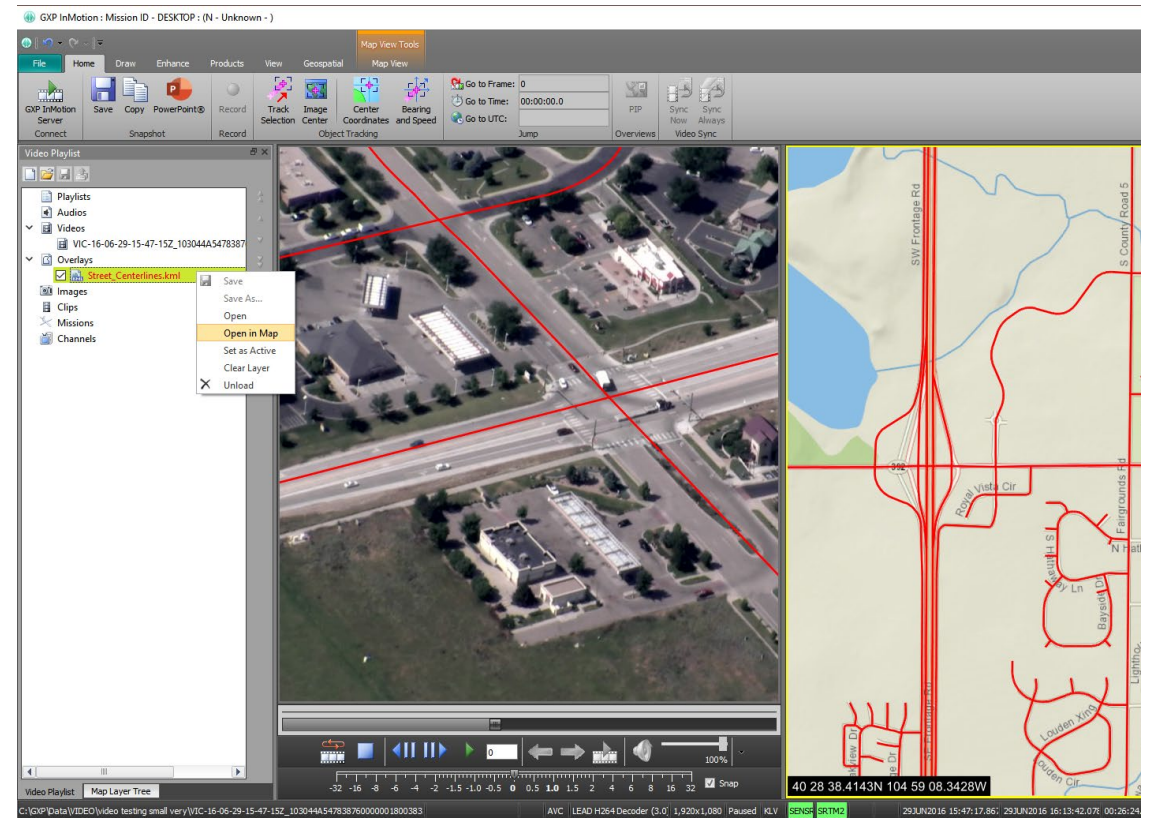

Imagery of MX-15 videos over Ft. Collins, CO; Courtesy of L-3 Communications, EO/IR Inc.

## Performance improvements for the Map Window

- The ability to display any layer of an Esri MapServer, ImageryServer, and FeatureServer in the GXP InMotion Map Window was added in v4.5.0.0.
- In GXP InMotion v4.5.0.1, performance improvements were realized for the Map Window that focused on the efficient handling of graphics vector data from both KMLs and shapefiles.

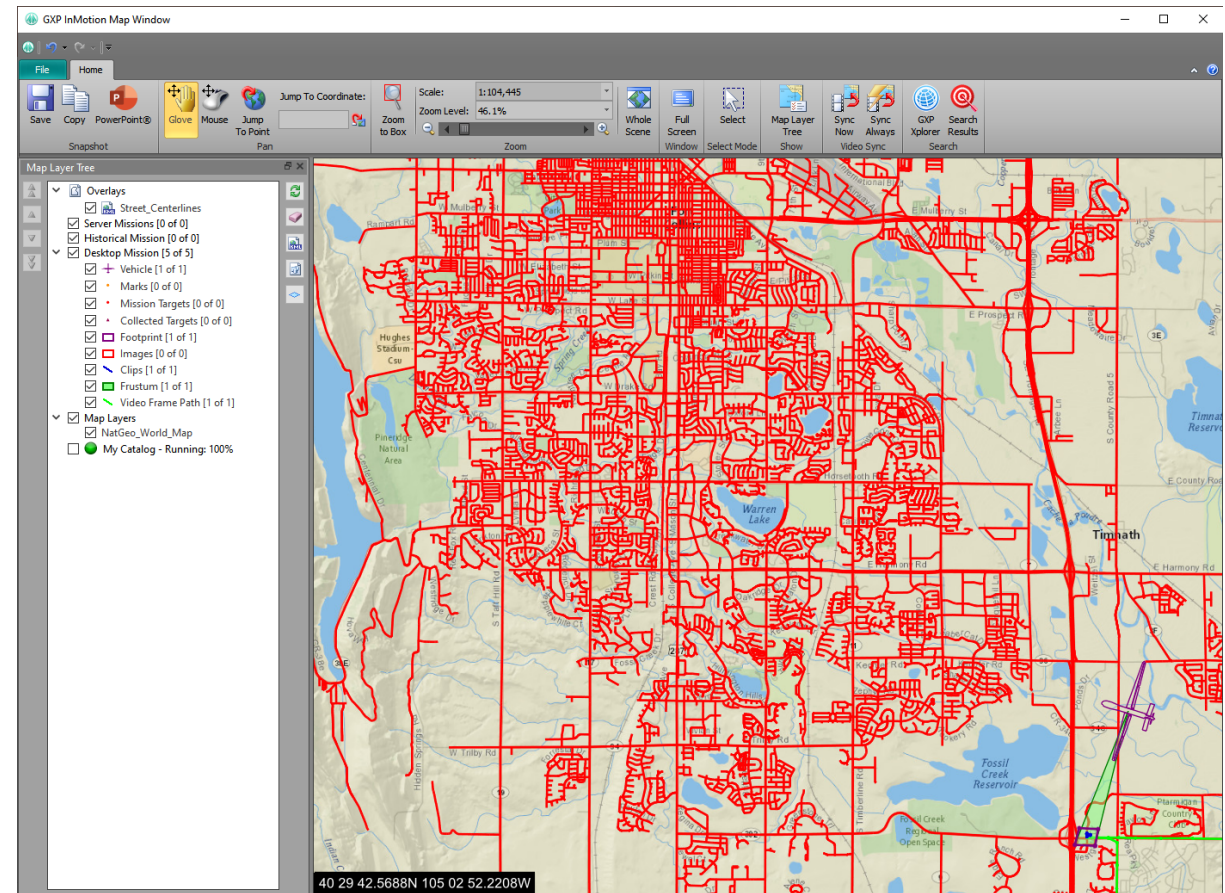

Imagery of MX-15 videos over Ft. Collins, CO; Courtesy of L-3 Communications, EO/IR Inc.

## Added the GXP Xplorer Terrain service to GXP InMotion

- The Autoload preference defines the directories used to access the Digital Terrain elevation Data (DTED) used within the video application.
- The advantage of enabling terrain elevation in the background of the video scene is that it provides enhanced sensor model support.
- Use the new GXP Xplorer Terrain Service in GXP InMotion preferences to stream terrain from the GXP Xplorer Platform into GXP InMotion.
- NOTE: The GXP Xplorer server terrain service requires the DTED cataloged on accessible network paths by the client workstation. If the network path isn't accessible to the client the network request may experience time out requests.

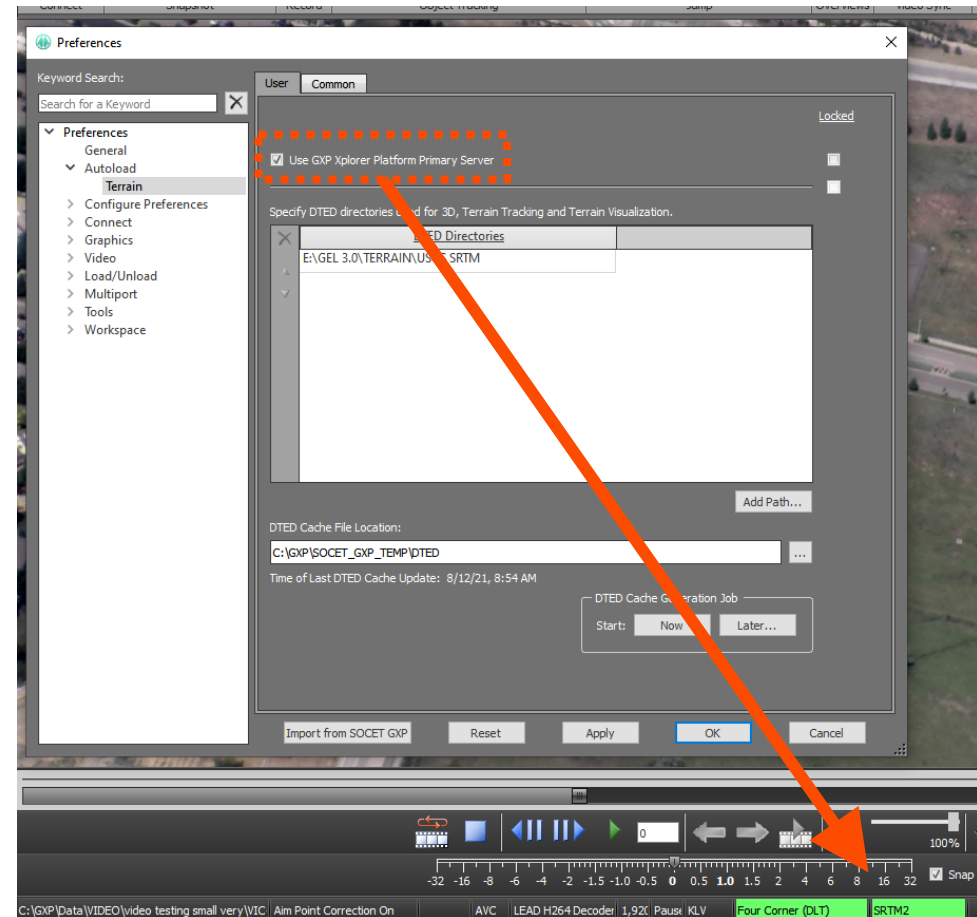

Imagery of MX-15 videos over Ft. Collins, CO; Courtesy of L-3 Communications, EO/IR Inc.

# Added 'Jump to Point' capabilities to GXP InMotion

- Use the new Jump to Point or Jump to Coordinate in GXP InMotion to navigate to a specific coordinate in the video scene. This functionality moves the cursor to an exact coordinate for a georeferenced video. The panel moves the cursor to the point of interest on the video (or off the video), and re-centers the video to display the coordinates not visible on the panel.
- Jump to Point will also place a marker at the location and display the coordinates using GXP's innovative auto labels capabilities.

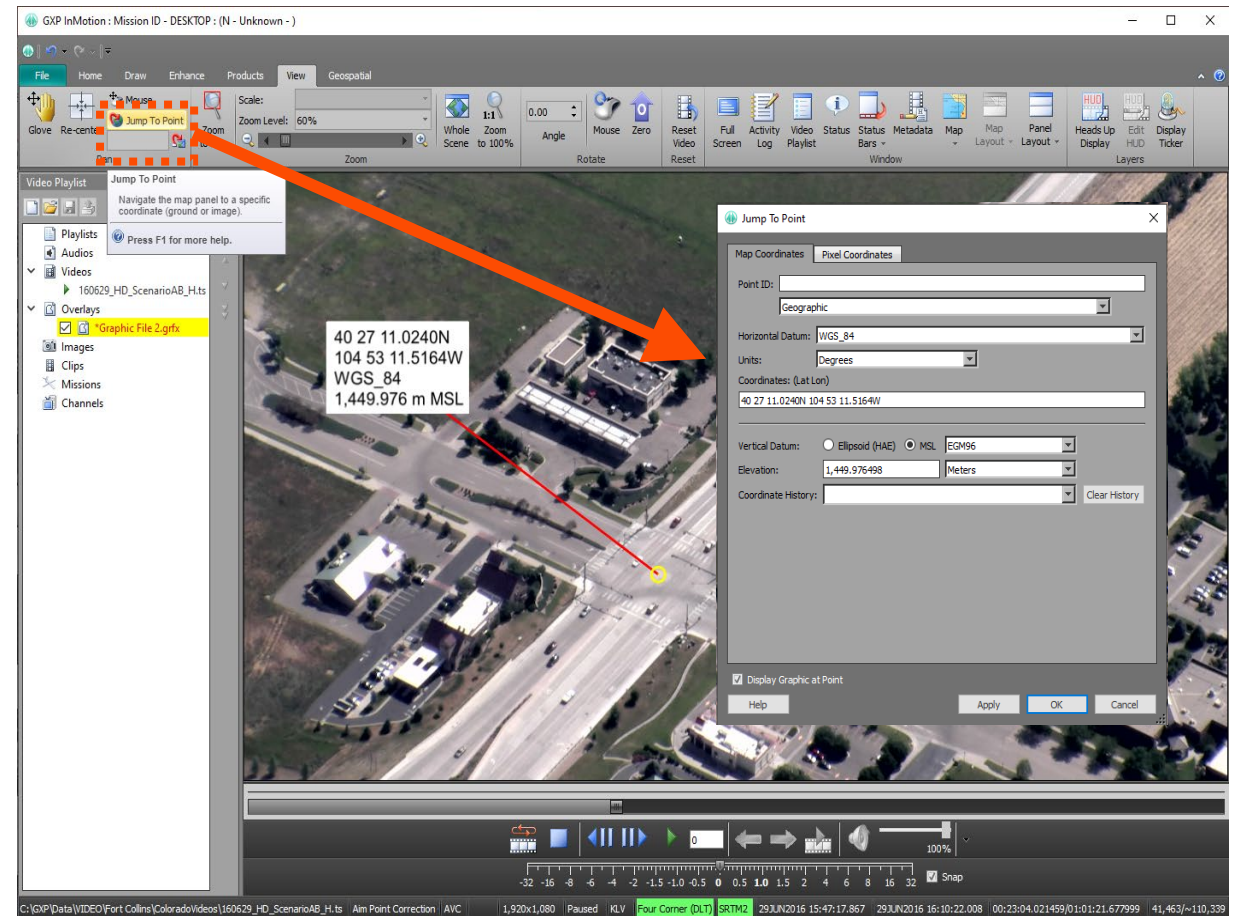

Imagery of MX-15 videos over Ft. Collins, CO; Courtesy of L-3 Communications, EO/IR Inc.

## Customize Ribbon

- Streamline access to commonly used tools by adding up to three user Ribbons that contain the functionality from other Ribbons relevant to your workflows.
- Simplify the GXP InMotion user interface by hiding groups of buttons or entire tabs of rarely used functionality.
- Create custom tabs with mix and match functionality from other tabs.

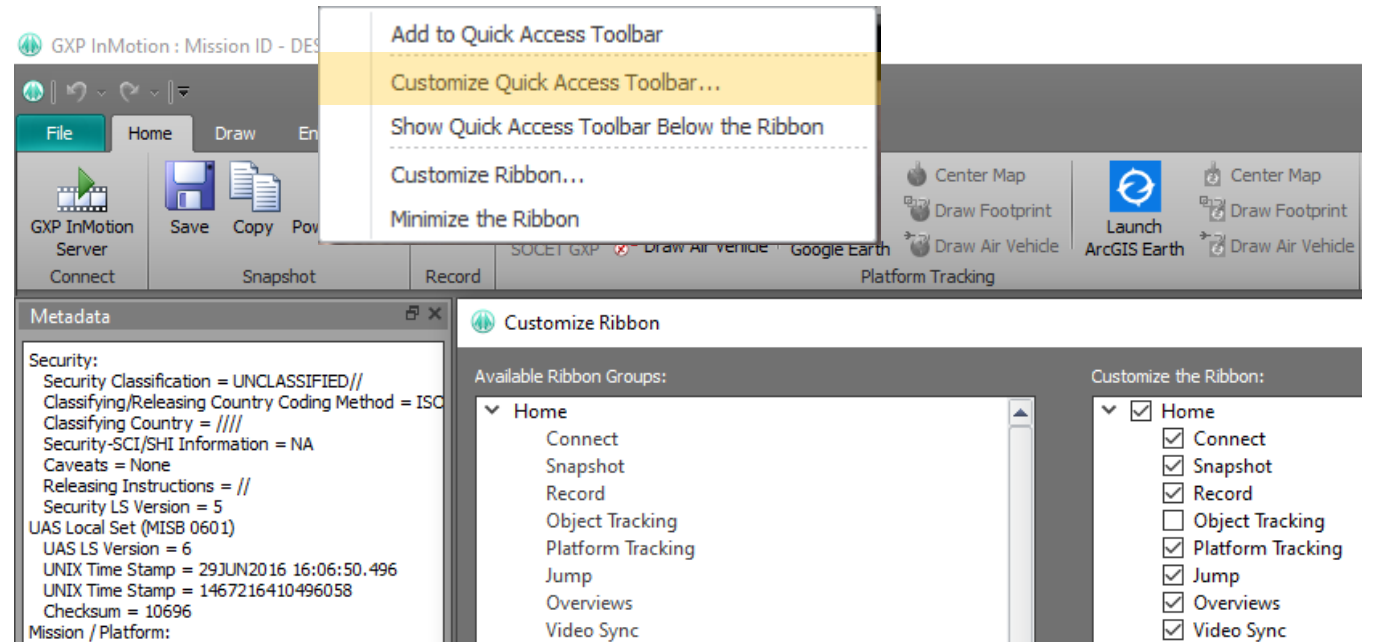



## GXP InMotion v4.5.0.1 – Video Encoder performance update

- In GXP InMotion v4.5.0.0, support was added to embed vector graphics into encoded videos.
- Vector graphic files are rather small in nature, but the graphical display and encoding of these files require the right amount of efficient resources.
- In GXP InMotion v4.5.0.1, the performance of the Video Encoder was improved to help support this new feature.

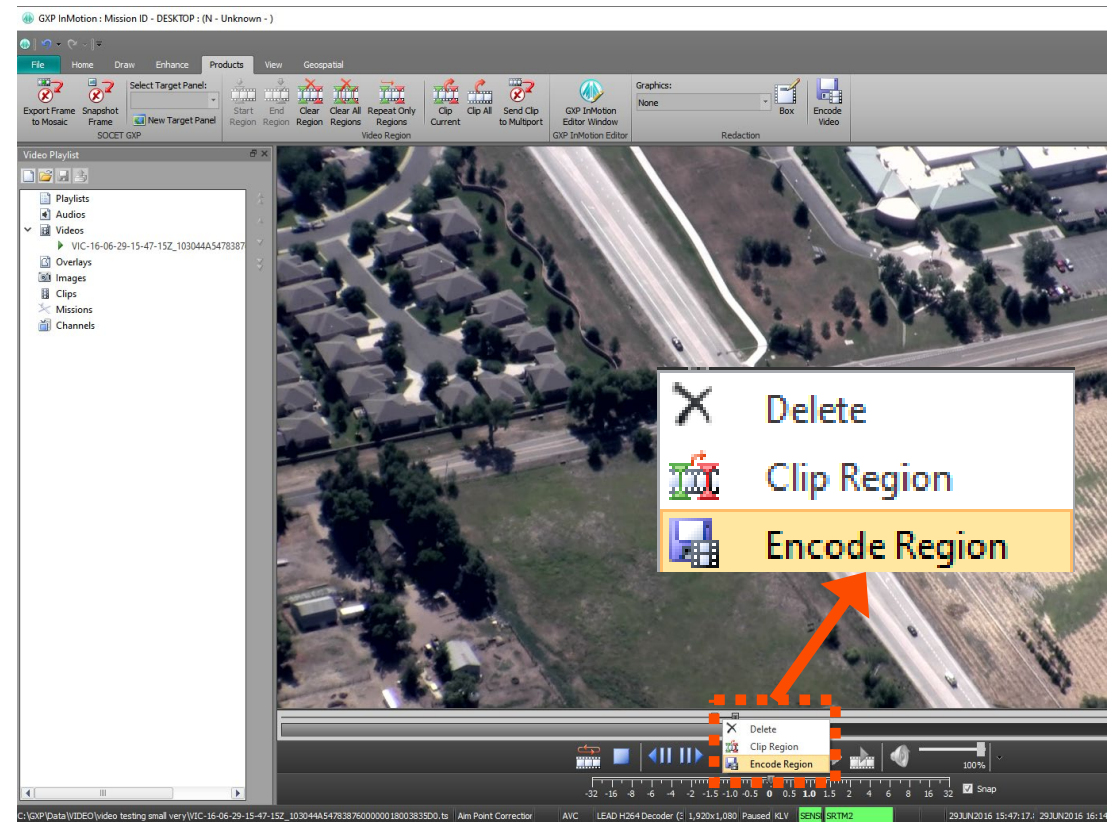

Imagery of MX-15 videos over Ft. Collins, CO; Courtesy of L-3 Communications, EO/IR Inc.

## GXP InMotion v4.5.0.4 – Mensuration

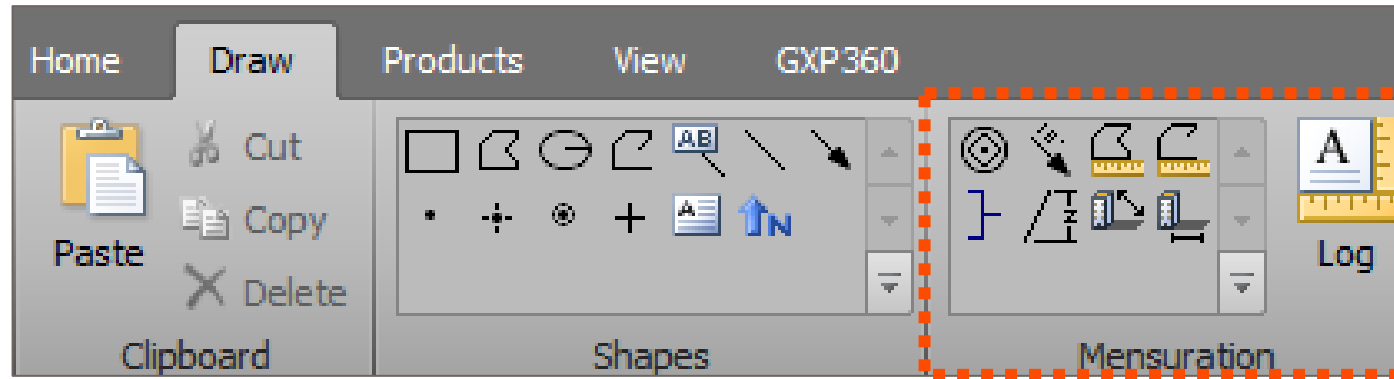

- Now available in v4.5.0.4 is the ability to perform mensuration capabilities directly over video, a capability normally reserved for imagery only. Mensuration can be performed over live feeds or forensic video files.
- The GXP InMotion video player can be paused, and users can measure length with the bracket tool, range and bearings calculations, polygon and polyline mensuration, use the Marker tool to denote CE/LE measurements, and height measurements (including via shadow tips to a feature object's base or top).

# GXP InMotion v4.5.0.4 – Range and Bearing Mensuration

The screenshot displays the GXP InMotion v4.5.0.4 software interface. The main window shows an aerial video frame of Ft. Collins, CO. A red arrow points from the 'Range and Bearing' tool icon in the 'Mensuration' toolbar to the 'Range and Bearing' tool icon. A second red arrow points from the 'Range and Bearing' graphic on the video frame to the 'Range and Bearing' tool icon. A third red arrow points from the 'Mensuration Log' window to the 'Mensuration Log' window.

**Range and Bearing 'Tool'**

**Range and Bearing 'Graphic'**

**Mensuration Log**

Range and Bearing  
Create a range and bearing graphic to provide direction. This is an arrow line which displays text measuring the distance (range) and clockwise angle from the north (bearing). To create multiple range and bearing graphics, double-click this control.  
Press F1 for more help.

Mensuration Log - U - Unclassified

```
#####
Video: VIC-16-06-29-15-47-15Z_103044A5478387600000018003835D0.ts
Time: 20160629T161056.49721600
Frame Number: 42,515

Operational Image Point(s):
VERTEX LINE (Y) SAMPLE (X)
1 688.991 713.938
2 490.917 683.885

ID=5,146,272, Type=Polyline, Name=Range And Bearing 5146272
SENSRA_FRAME, WGS_84, MSL (EGM96)

COORDINATES
VERTEX 1 40 28 46N 104 59 19W Elev: 4,904.3 ft
VERTEX 2 40 28 48N 104 59 19W Elev: 4,894.2 ft

MEASUREMENTS VERTICES 1 2
RANGE (XY) 72.191 m 236.848 ft
RANGE (XYZ) 72.257 m 237.064 ft
ELEVATION RELIEF -3.085 m -10.123 ft
SLOPE
Percentage -4.273%
Ratio -1:23
Angle -2.447 deg
BEARING 000.196 deg

TOTALS
RANGE (XY) 72.191 m 236.848 ft
RANGE (XYZ) 72.257 m 237.064 ft
-----
```

Imagery of MX-15 videos over Ft. Collins, CO; Courtesy of L-3 Communications, EO/IR Inc.

# GXP InMotion v4.5.0.4 – Bracket Mensuration

The screenshot displays the GXP InMotion v4.5.0.4 software interface. The main window shows an aerial video frame with a white bracket graphic overlaid on a road intersection. A yellow callout box labeled "Bracket 'Tool'" points to the Bracket tool icon in the software's toolbar. Another yellow callout box labeled "Bracket 'Graphic'" points to the bracket graphic on the video. A third yellow callout box labeled "Mensuration Log" points to a separate window titled "Mensuration Log - U - Unclassified". This window displays the following data:

```

#####
Video: VIC-16-06-29-15-47-15Z_103044A5478387600000018003835D0.ts
Time: 20160629T161056.49721600
Frame Number: 42,515

Operational Image Point(s):
  VERTEX  LINE (Y)      SAMPLE (X)
  1         614.776      666.187
  2         616.592      736.134

ID=5,134,259, Type=Polyline, Name=Bracket 5134259
SENSRA_FRAME, WGS_84, MSL (EGM96)

COORDINATES
  VERTEX 1          40 28 47N 104 59 20W Elev: 4,901.6 ft
  VERTEX 2          40 28 47N 104 59 19W Elev: 4,901.6 ft

MEASUREMENTS VERTICES 1 2
  LENGTH (XY)              13.644 m  44.763 ft
  SLANT LENGTH (XYZ)       13.644 m  44.763 ft
  ELEVATION RELIEF         0.001 m  0.003 ft
  SLOPE
    Percentage              0.006%
    Ratio                   1:15,970
    Angle                   0.004 deg
    AZIMUTH                 093.167 deg

TOTALS
  DISTANCE (XY)            13.644 m  44.763 ft
  DISTANCE (XYZ)          13.644 m  44.763 ft
  -----
    
```

Imagery of MX-15 videos over Ft. Collins, CO; Courtesy of L-3 Communications, EO/IR Inc.

# GXP InMotion v4.5.0.4 – Height Mensuration

The screenshot displays the GXP InMotion v4.5.0.4 software interface. The main window shows an aerial video frame of a residential area. A yellow callout box labeled "Height 'Tool'" points to the "Mensuration" icon in the top toolbar. A second yellow callout box labeled "Height 'Graphic'" points to a white bracket drawn on a building in the video, with a red arrow pointing to the text "34.0 ft" displayed below it. A third yellow callout box labeled "Mensuration Log" points to a separate window titled "Mensuration Log - U - Unclassified". This window displays the following data:

```

ID=5,144,648, Type=Polyline, Name=Bracket 5144648
SENSRA_FRAME, WGS_84, MSL(EGM96)

COORDINATES
VERTEX 1          40 28 45N 104 59 20W Elev: 4,907.1 ft
VERTEX 2          40 28 45N 104 59 20W Elev: 4,941.2 ft

HEIGHT MEASUREMENTS
10.375 m 34.040 ft
-----

#####
Video: VIC-16-06-29-15-47-15Z_103044A5478387600000018003835D0.ts
Time: 20160629T161056.49721600
Frame Number: 42,515

Operational Image Point(s):
VERTEX  LINE (Y)      SAMPLE (X)
1         745.714         663.748
2         701.641         666.424

ID=5,144,648, Type=Polyline, Name=Bracket 5144648
SENSRA_FRAME, WGS_84, MSL(EGM96)

COORDINATES
VERTEX 1          40 28 45N 104 59 20W Elev: 4,907.1 ft
VERTEX 2          40 28 45N 104 59 20W Elev: 4,941.2 ft

HEIGHT MEASUREMENTS
10.375 m 34.040 ft
-----
    
```

Imagery of MX-15 videos over Ft. Collins, CO; Courtesy of L-3 Communications, EO/IR Inc.

# GXP InMotion v4.5.0.4 – Height from Shadows Mensuration

Height from Shadows 'Tool'

Height from Shadows 'Graphic'

Step 1: Click at top of feature  
Step 2: Move to shadow

Step 3: Draw out to position

Step 4: Click to Finish

35.124 ft

34.479 ft

35.1 ft

Mensuration Manage

Height Measurement: Object Top to Shadow Tip

Compute the height of an object by measuring its shadow from the top of the object to the tip of the shadow.

Mensuration Manage

Height Measurement: Object Base to Shadow Tip

Compute the height of an object by measuring its shadow from the base of the object to the tip of the shadow.

Imagery of MX-15 videos over Ft. Collins, CO; Courtesy of L-3 Communications, EO/IR Inc.

# GXP InMotion v4.5.0.4 – Polygon/Polyline Mensuration

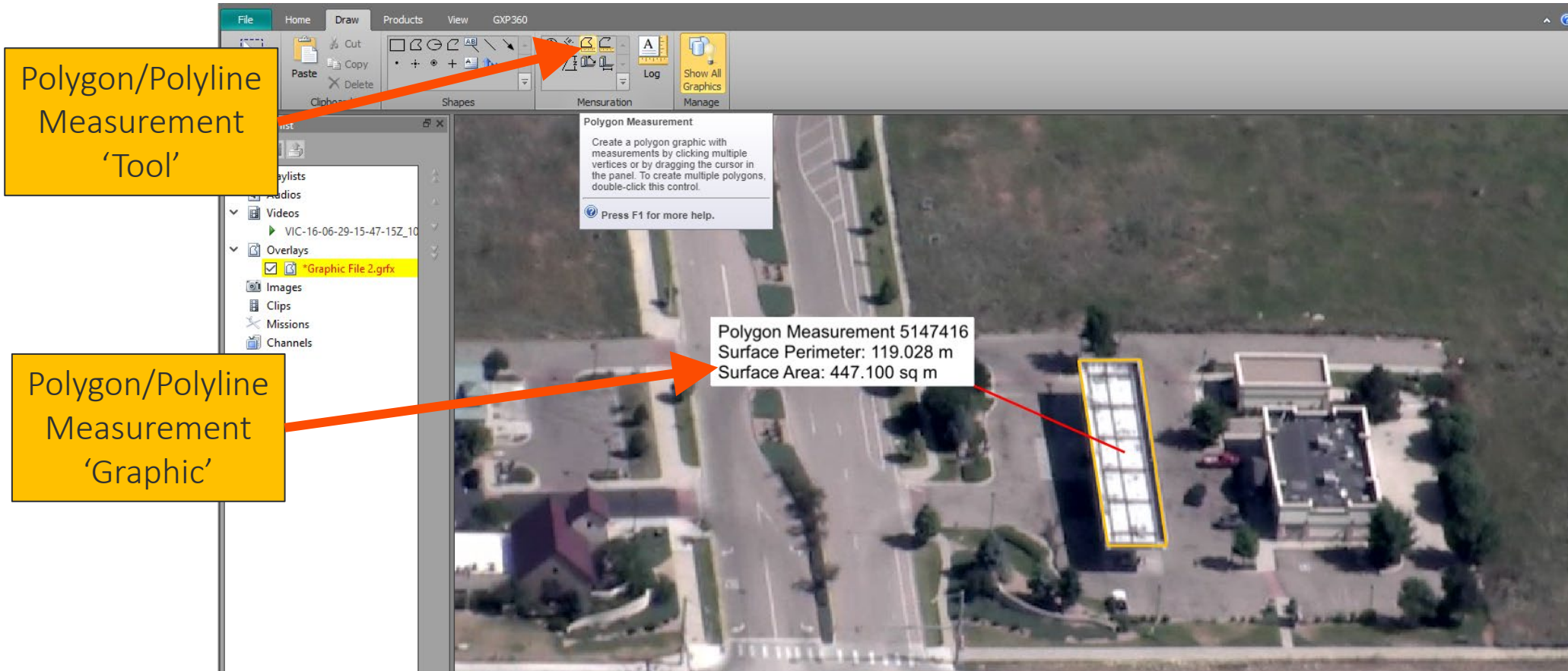

Imagery of MX-15 videos over Ft. Collins, CO; Courtesy of L-3 Communications, EO/IR Inc.

# GXP InMotion v4.5.0.4 – CE/LE Notation

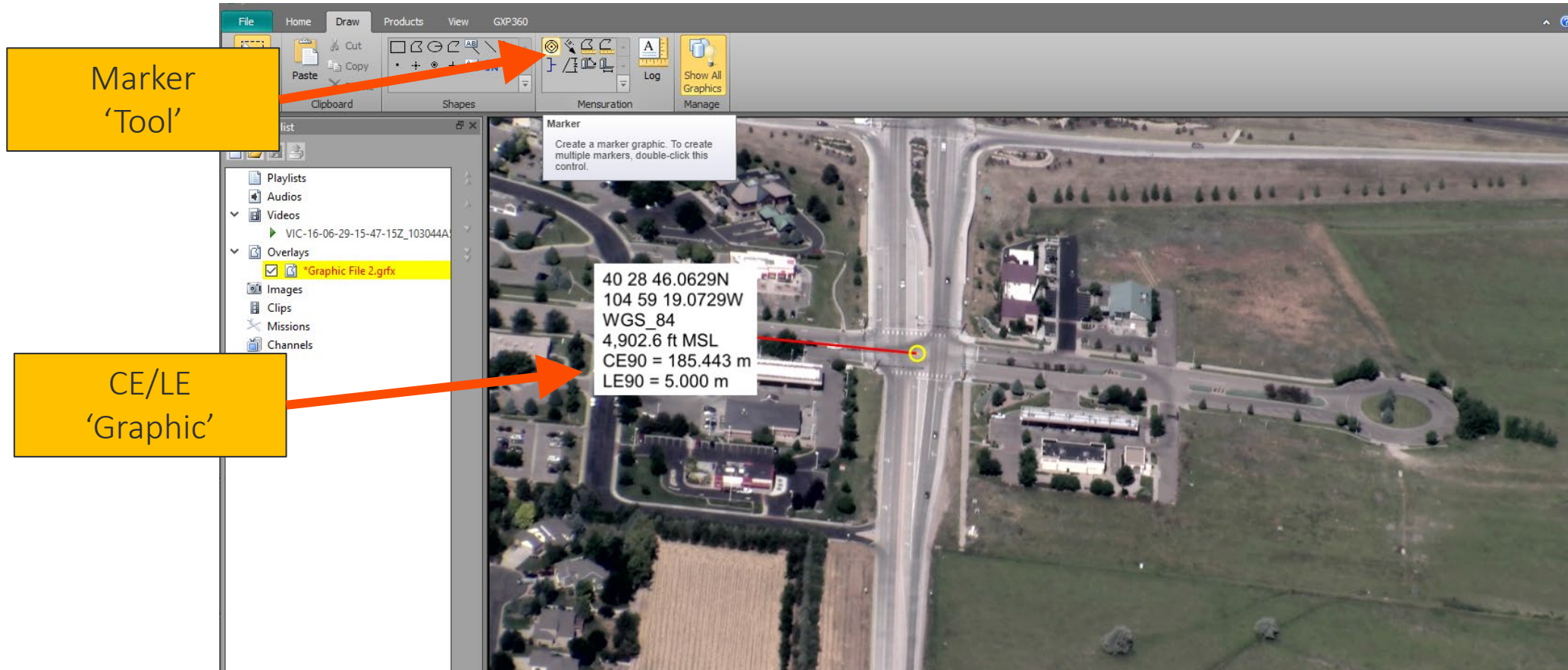

Imagery of MX-15 videos over Ft. Collins, CO; Courtesy of L-3 Communications, EO/IR Inc.



## GXP InMotion v4.5.0.4 – Drawing order for graphics in video view

- The playlist now supports ‘drawing order’ for graphics.
- Drawing order allows for moving vector graphics up and down in the video player for better layer management.
- Supported vector formats include:
  - Shapefiles,
  - KML/KMZ files,
  - GXP native Graphics files.

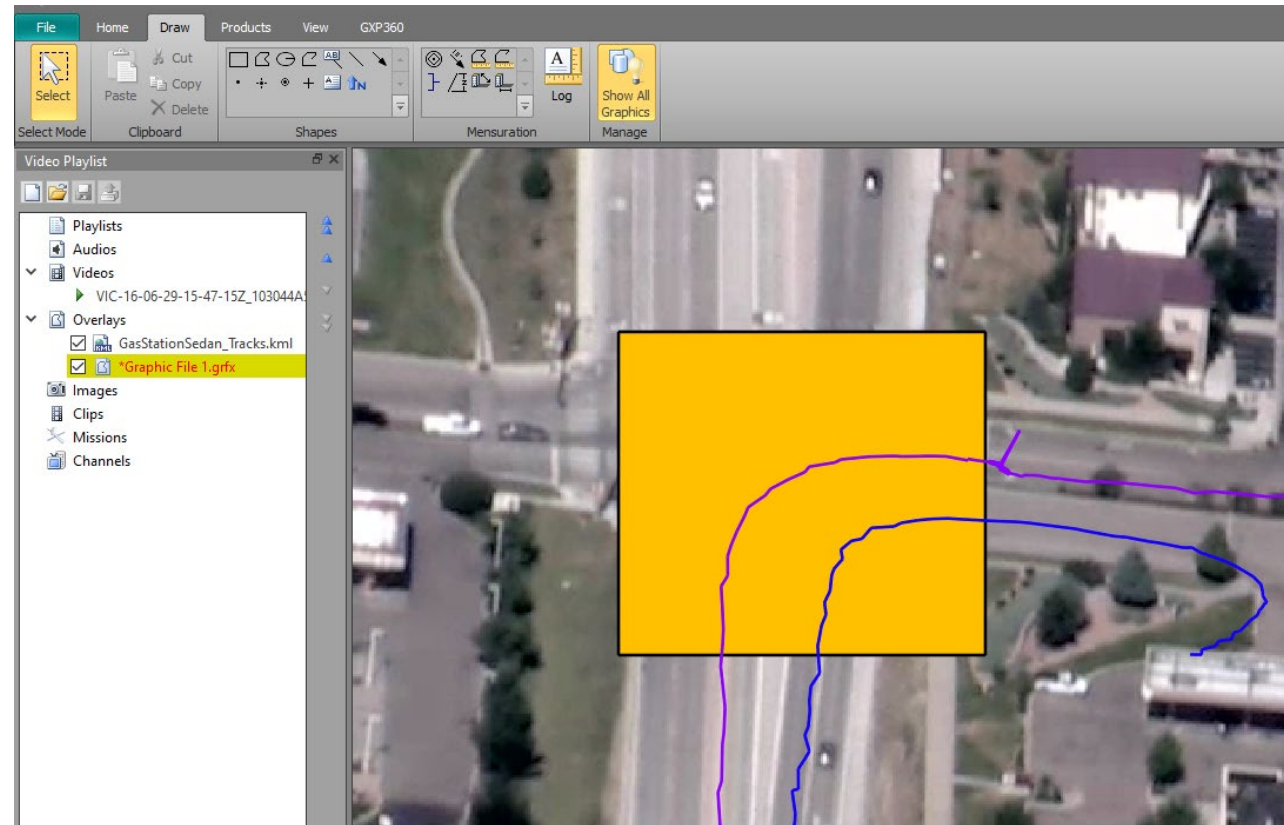

Imagery of MX-15 videos over Ft. Collins, CO; Courtesy of L-3 Communications, EO/IR Inc.

## GXP InMotion v4.5.0.4 – Amended KLV data support

- ‘Amended’ KLV data could be KLV data that has been manipulated from the original data, for example, during georegistration.
- The KLV metadata can be augmented to simultaneously preserve the original metadata while providing updated information.
- Adjusting the user preferences can force GXP InMotion to ignore the augmented or amended KLV metadata and only employ the original KLV metadata.

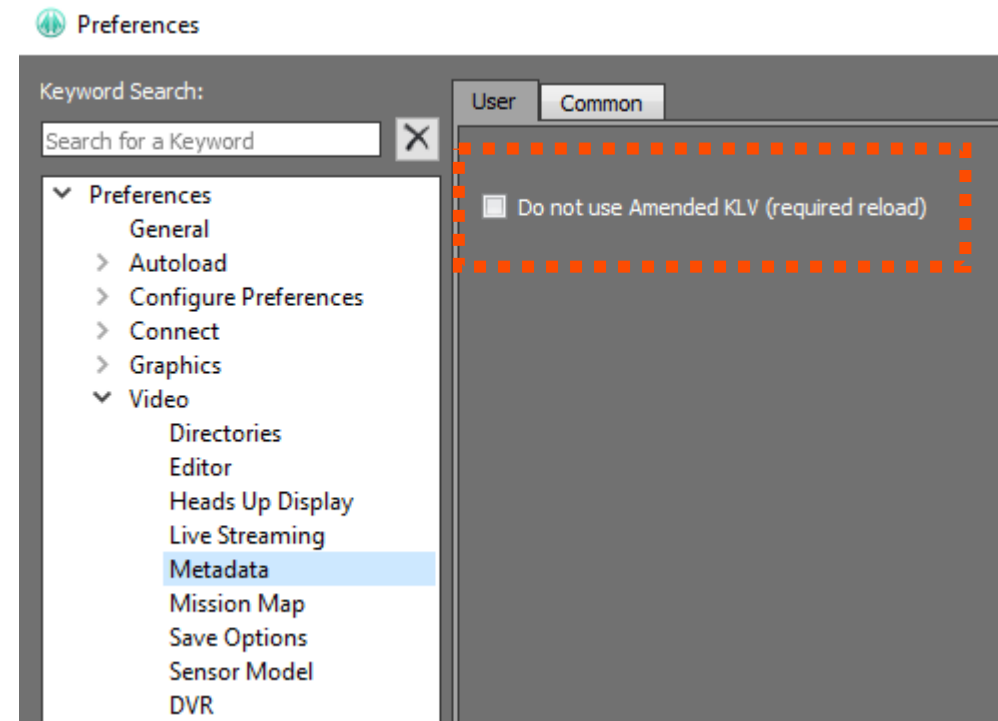

# GXP InMotion v4.5.0.5 – Export multipanel video as a single clip

- Users can now record multiple video panels at once and export as a single clip.

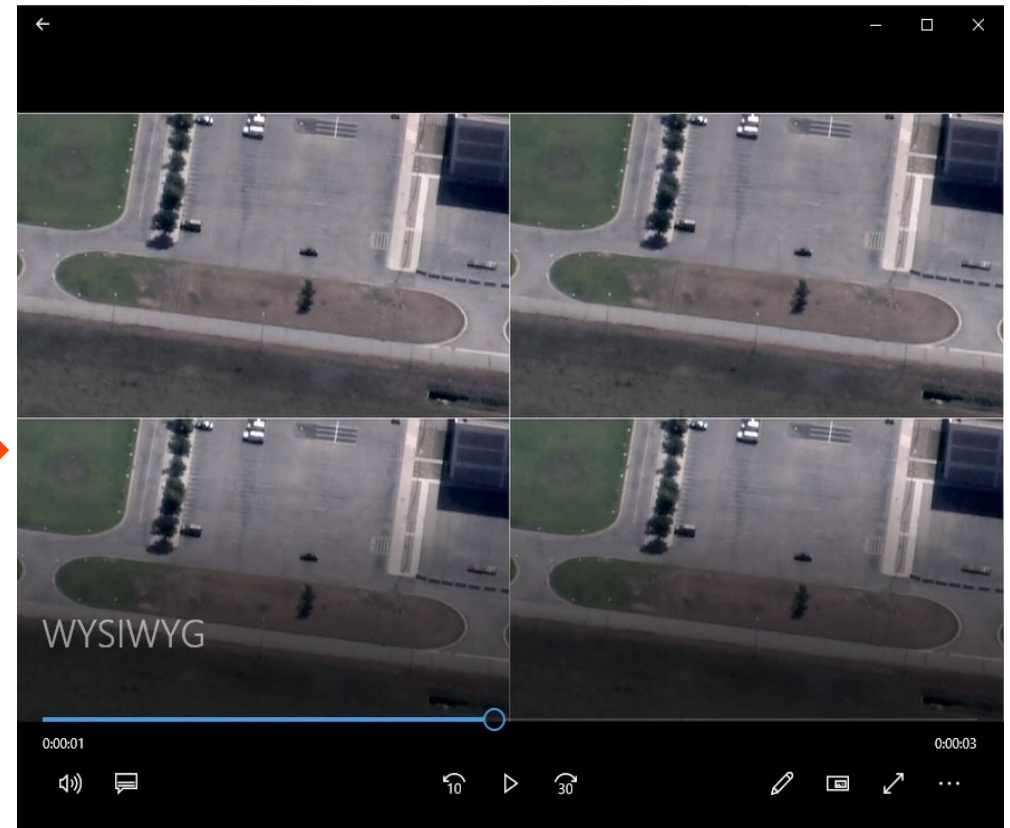
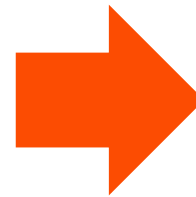
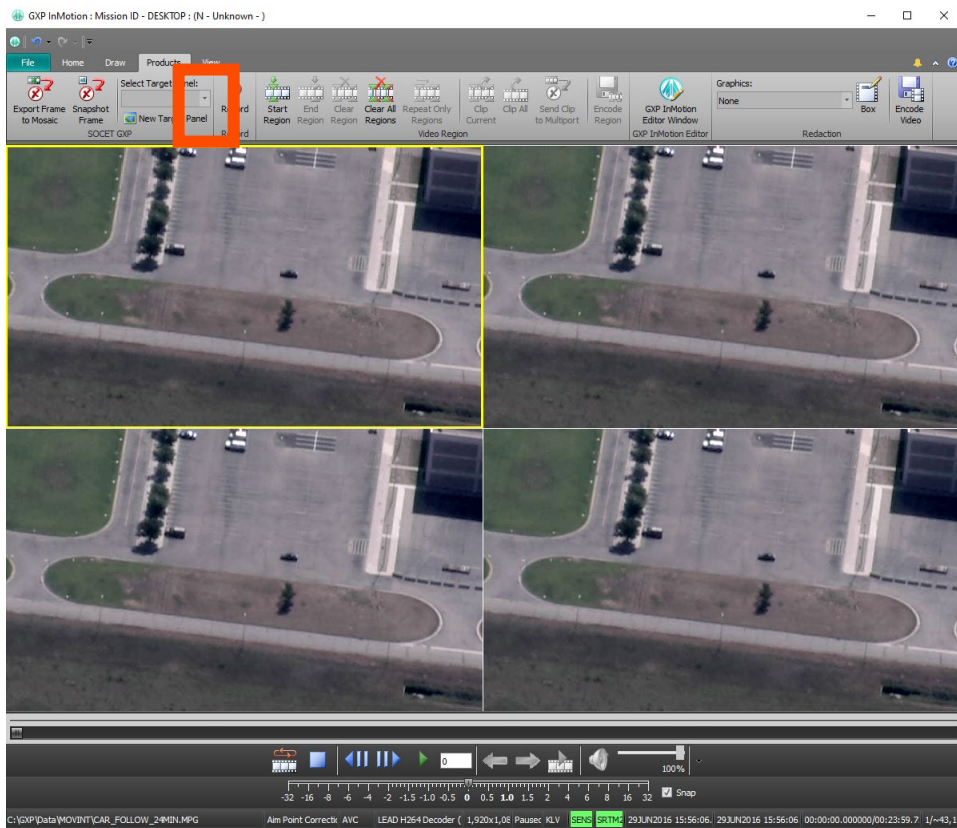

Imagery of MX-15 videos over Ft. Collins, CO; Courtesy of L-3 Communications, EO/IR Inc.

## GXP InMotion v4.5.0.5 – Activity Collection date/time by analyst

- The Activity Log by default records a number of attributes during a mission. For example, Analytical Comments, Coordinates, Platform information, etc.
- The attribute ‘Video time’ records when a user makes an observation in relation to the original video’s time collection.
- The attribute ‘Collection Time’ was added for activities to record the time an analyst makes the remark, independent of the video time. This aids quality control for forensic videos.

|   | Analytical Comments | Video Time GMT           | Collection Time          | Center Coordinate    | Derive |
|---|---------------------|--------------------------|--------------------------|----------------------|--------|
| 1 | On Mission          | Jun 29, 2016, 3:09:51 AM | Sep 7, 2022, 11:03:08 AM | 40 28 12N 104 53 20W | C182   |
| 2 | gas station         | Jun 29, 2016, 4:05:30 AM | Sep 7, 2022, 11:03:24 AM | 40 28 47N 104 55 18W | C182   |
| 3 | End Mission         | Jun 29, 2016, 4:18:20 PM | Sep 7, 2022, 11:03:34 AM | 40 26 34N 104 58 57W | C182   |

Imagery of MX-15 videos over Ft. Collins, CO; Courtesy of L-3 Communications, EO/IR Inc.

## GXP InMotion v4.5.0.5 – Preferences added

- Added the following Preferences:
  - Bracket Measurement Preferences.
  - Measurement Graphic Preferences for Polygon and Polyline.

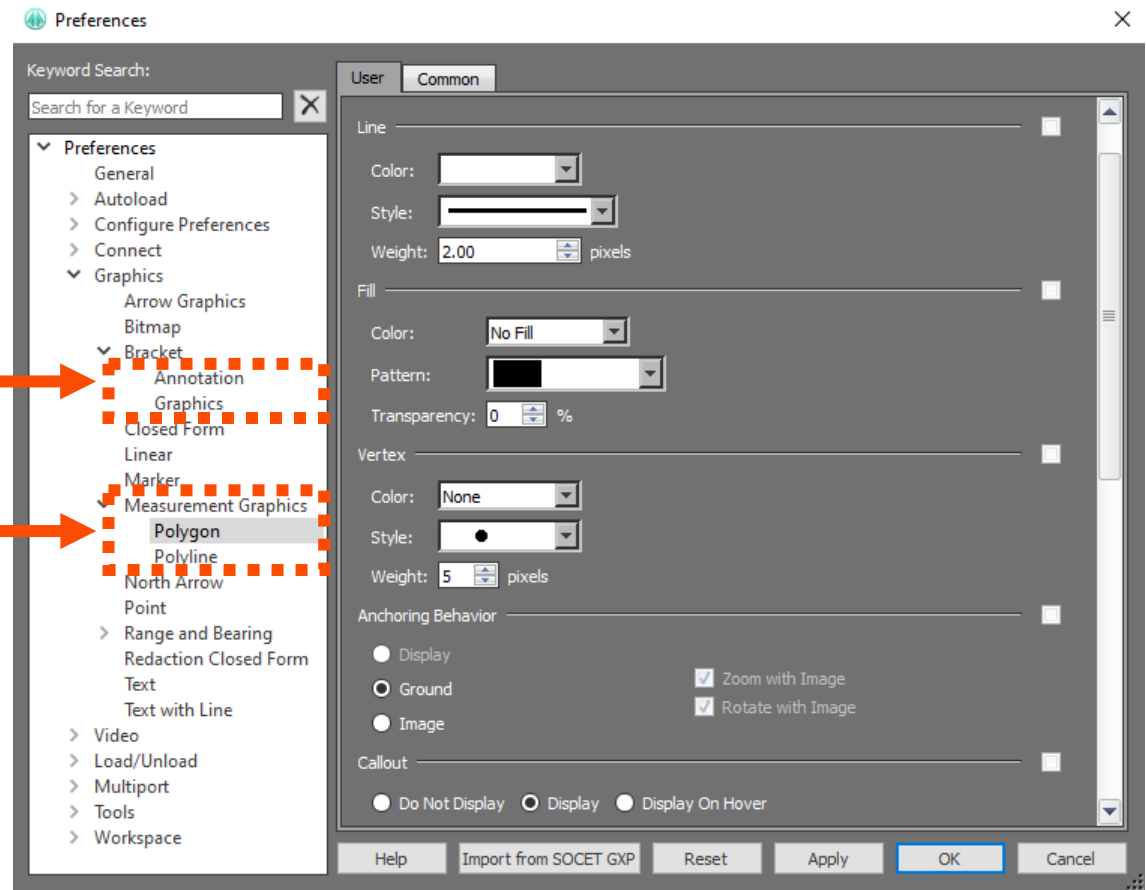

# GXP InMotion v4.5.0.6 – Changed ‘Target’ references to ‘Objective’

- Multiple locations in the User Interface, references to ‘Target’ have been replaced with ‘Objective’.

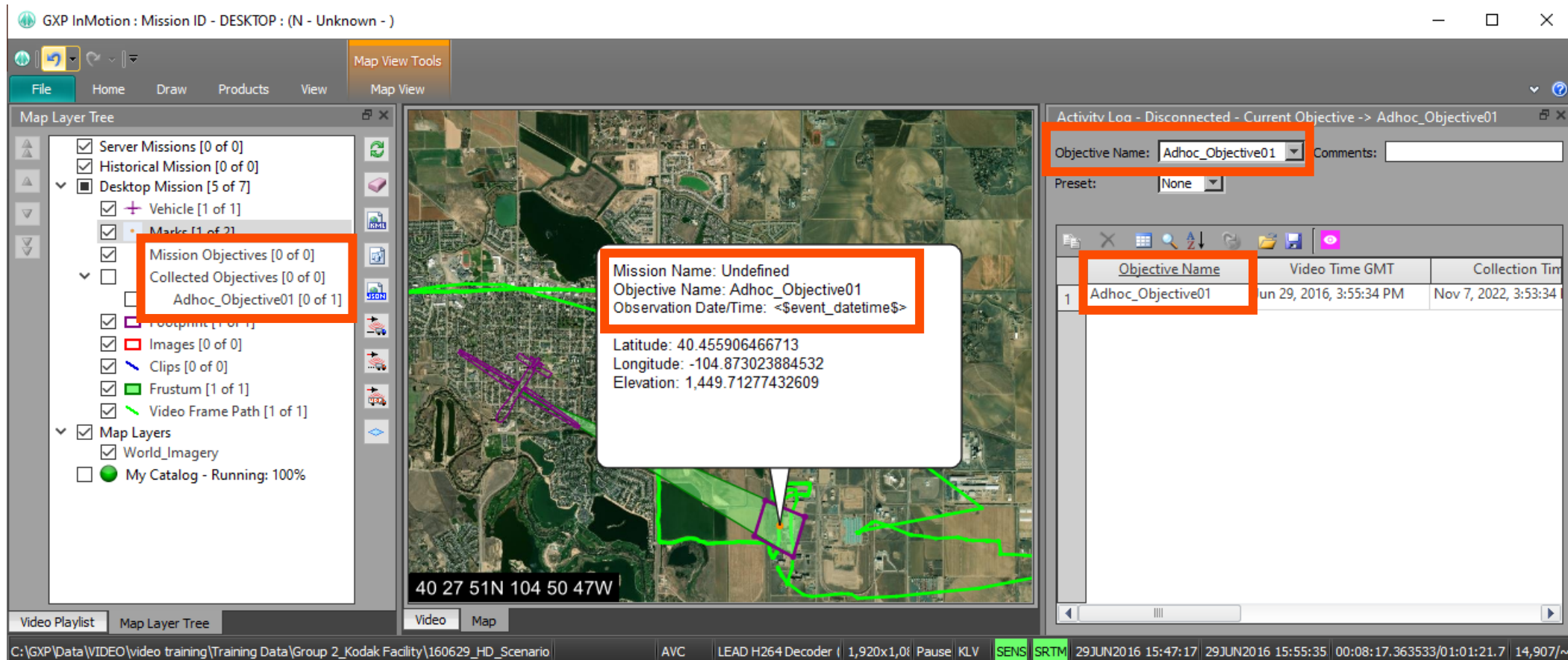

Imagery of MX-15 videos over Ft. Collins, CO; Courtesy of L-3 Communications, EO/IR Inc.

# GXP InMotion v4.5.0.7 – Export multiple frames with one button click!

- Users can now snapshot multiple video panels at once and export all panels at once.
- Clicking the new ‘Export All Panels’ button on the Products tab will snapshot a frame from each open panel.
- Snapshots are sent to one folder based on the file type set in preferences.
- Snapshots also appear in the Images subsection of the Video Playlist.

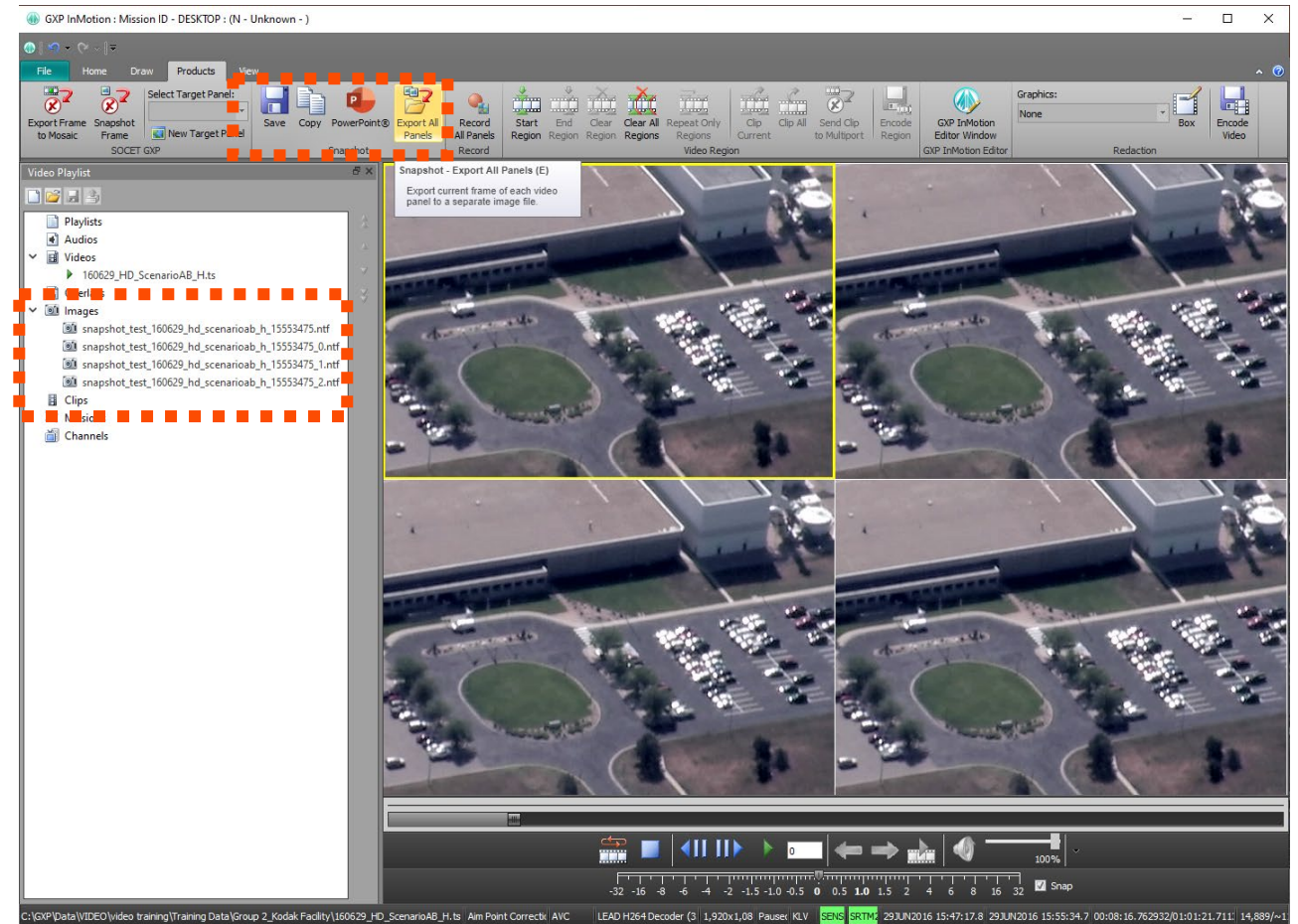

Imagery of MX-15 videos over Ft. Collins, CO; Courtesy of L-3 Communications, EO/IR Inc.

## Pre-GXP InMotion v4.5.1.0 – MIE4NITF updates

- Available in v4.4.1.3.
  - Integrate MSP sensor models for MIE4NITF imagery.
  - MIE4NITF metadata to Snapshot/Chip NITF Output Files.
- Available in v4.5.0.1.
  - Add support for MIE4NITF derived shapefile overlays and 4676/XML.
  - Display MIE4NITF footprint in the Map Window.
  - Jump To Point/Coordinate available for MIE4NITF.
- Available in v4.5.0.2.
  - MIE4NITF derived shapefile overlays in video scene.
  - WYSIWYG (What You See Is What You Get) clipping/encoding of MIE4NITF out to standard video formats.

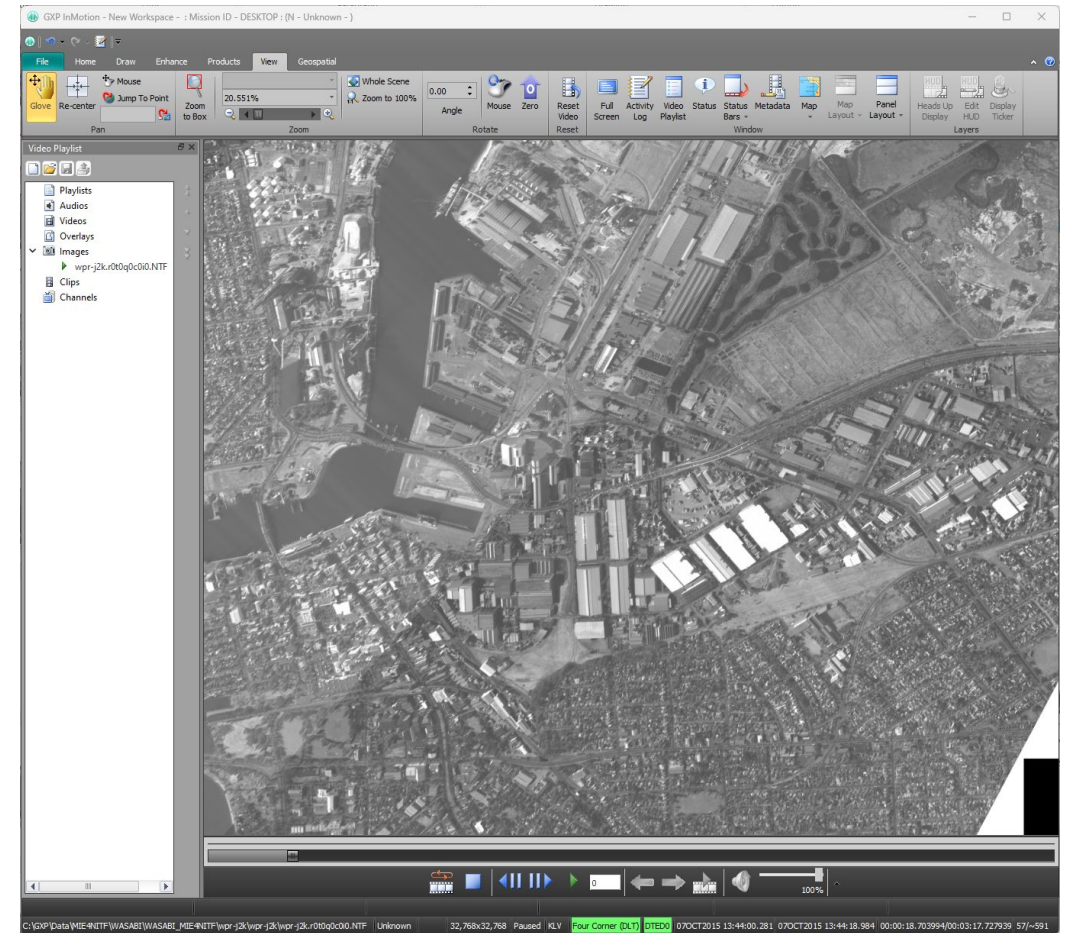

The WASABI MIE4NITF sample data set is a subset of the larger Public Release Data set from the WASABI effort that contains imagery collected over the Adelaide CBD and Port Adelaide areas. The AngelFire sensor is owned by the WASABI program partner National Geospatial Agency (NGA), USA.



# Pre-GXP InMotion v4.5.1.0 – MIE4NITF updates ...2

- Available in v4.5.0.3.
- Open Geospatial Consortium (OGC) based MIE4NITF data streams.
  - This feature will allow the desktop to utilize an OGC/ Wide Area Motion Imagery (WAMI) server to retrieve a full WAMI collection (of images) and play it back like local WAMI files.
  - Retrieve basic "video" metadata including time bounds, geo-spatial bounds and number of frames.
  - Load each image with sensor model.
  - Provide pan, zoom, and rotate on dataset.
  - Play at the native frame rate.

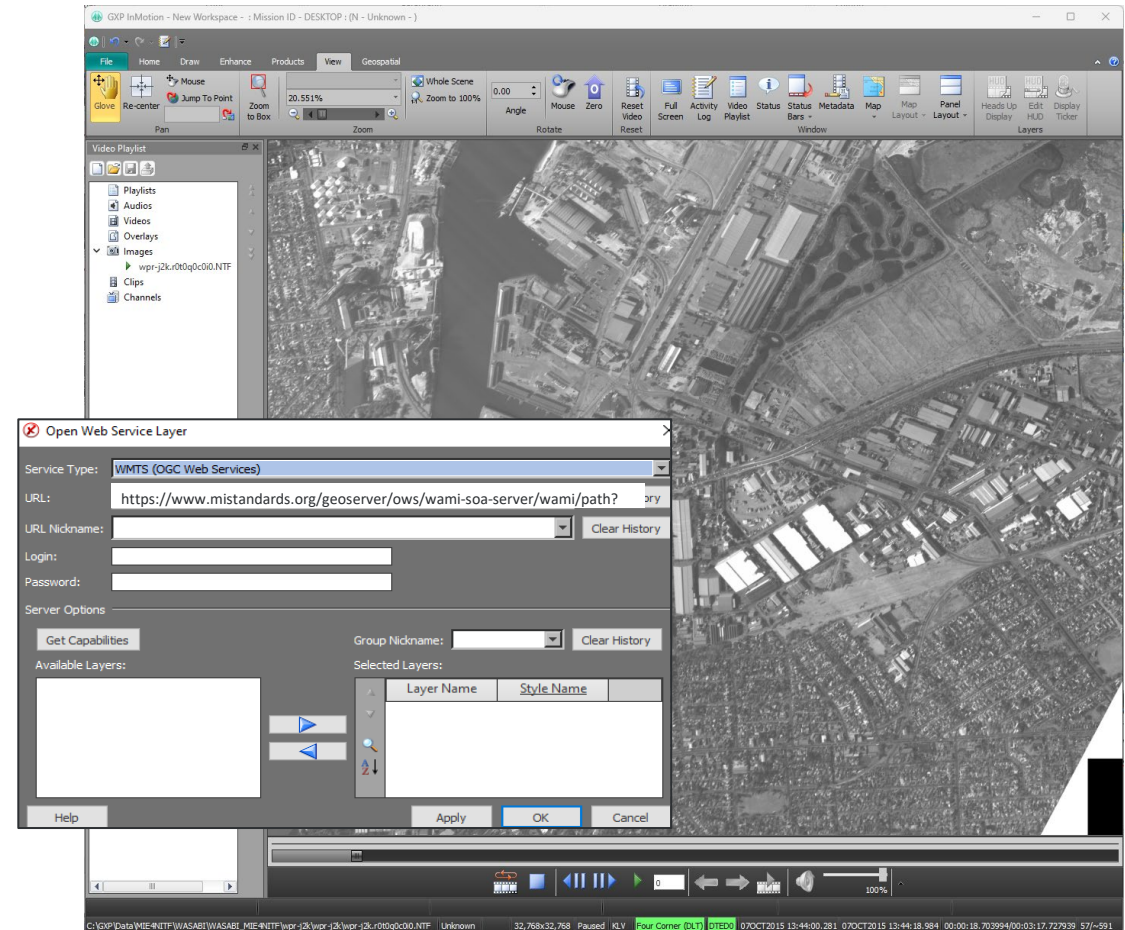

The WASABI MIE4NITF sample data set is a subset of the larger Public Release Data set from the WASABI effort that contains imagery collected over the Adelaide CBD and Port Adelaide areas. The Angelfire sensor is owned by the WASABI program partner National Geospatial Agency (NGA), USA.

## GXP InMotion v4.5.1.0 – MIE4NITF updates

- Available in v4.5.1.0.
  - Added support for MIE4NITF with embedded H264 files.
  - Associate STANAG-4676 B tracking data files to corresponding image frames in video scene.
    - The NATO “*standard for transmitting and sharing track information; this standard is known as STANAG 4676. It defines a track as a set of associated state vector estimates describing the time-sequenced location, velocity, acceleration, and other relevant characteristics of a mobile object or group of objects.*” Reference - OGC OWS-8 Tracking: Moving Target Indicator Process, Workflows and Implementation Results ER.
    - The corresponding track data is spatially and temporally displayed with the underlying pixel data and only the detections are displayed when playing the data as opposed to a track. This creates an optimal way for users to exploit the data temporally.

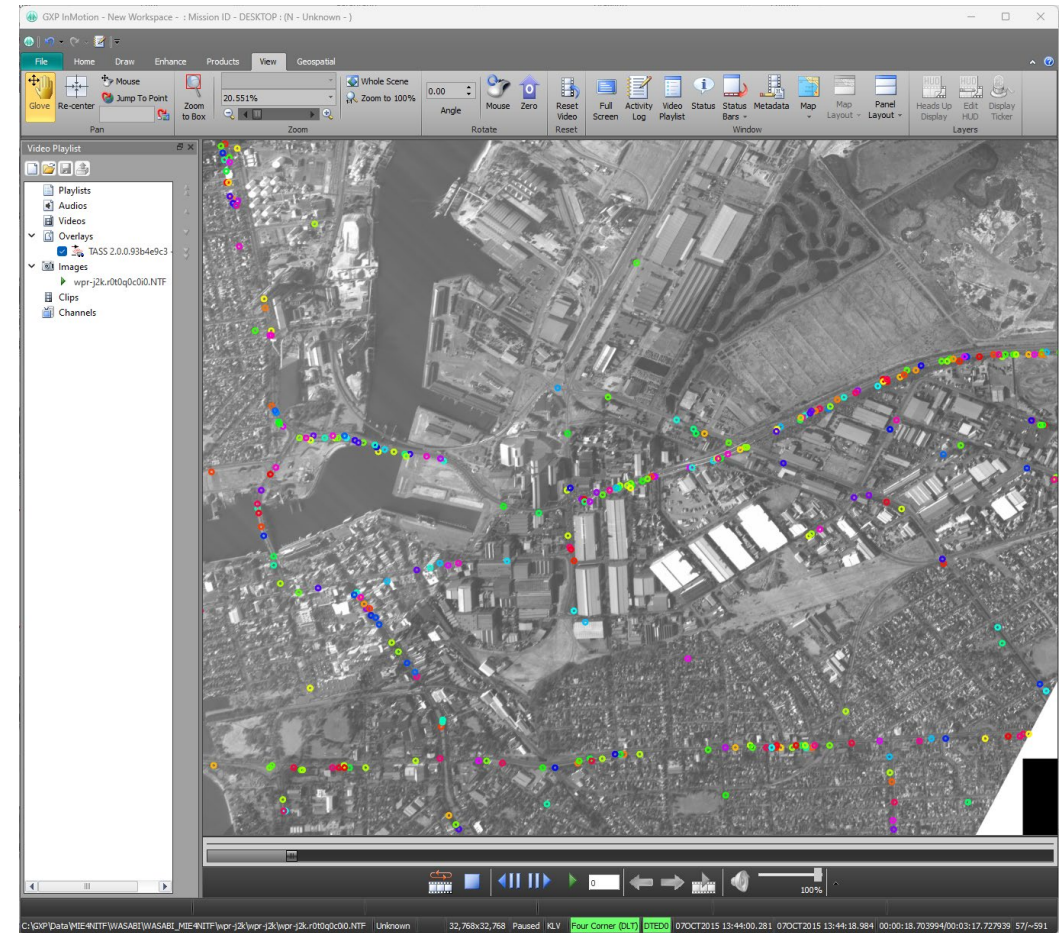

The WASABI MIE4NITF sample data set is a subset of the larger Public Release Data set from the WASABI effort that contains imagery collected over the Adelaide CBD and Port Adelaide areas. The AngelFire sensor is owned by the WASABI program partner National Geospatial Agency (NGA), USA.

## GXP InMotion v4.5.1.0 – 4676 detection Selection and Follow

- Added the capability to select 4676B dots (detections) in the video panel and a new button for 'Follow Selected'.
- This is similar to how the map window centers on the platform for FMV, but this new capability is centering on the 4676B detection, or 4607, within the video scene. Users are able to select a detection, click 'Follow Selected', then click the Play button and the background data (MIE4NITF) moves while the detection remains fixed.
- The new 'dot' selection capability lays the foundation that will be used for displaying details and editing tracks in the future.

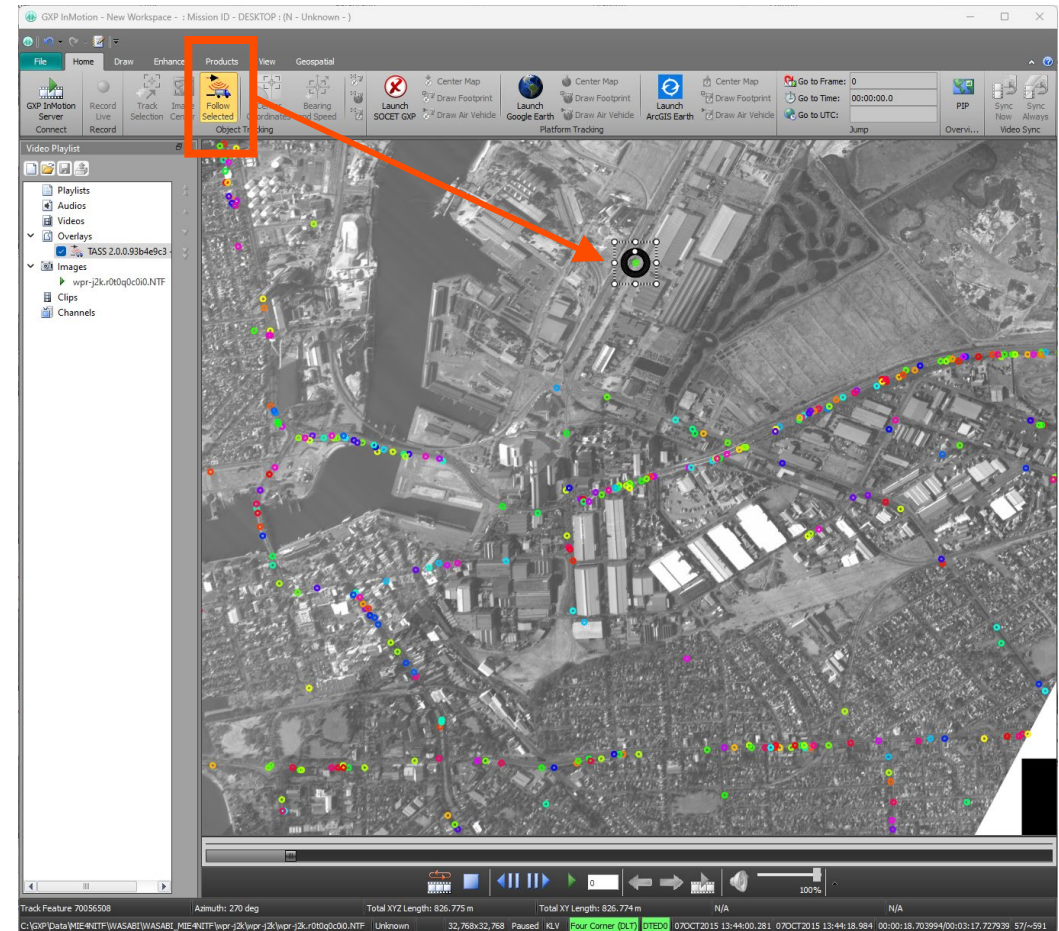

The WASABI MIE4NITF sample data set is a subset of the larger Public Release Data set from the WASABI effort that contains imagery collected over the Adelaide CBD and Port Adelaide areas. The AngelFire sensor is owned by the WASABI program partner National Geospatial Agency (NGA), USA.

## GXP InMotion v4.5.1.0 – Enhancements to Historical Mission query

- New enhancements to Historical Mission queries include:
  - As a performance improvement, limit Missions query and results to the Mission Range UI Selection.
  - Allow the user to select a range of dates for missions to be displayed in the historic mission dropdown.
    - The historic range selection has been replaced by two date dropdowns.
    - The date dropdowns shall be pre-populated with the range of today's date and three days ago.
    - The results returned should be inclusive of both dates.

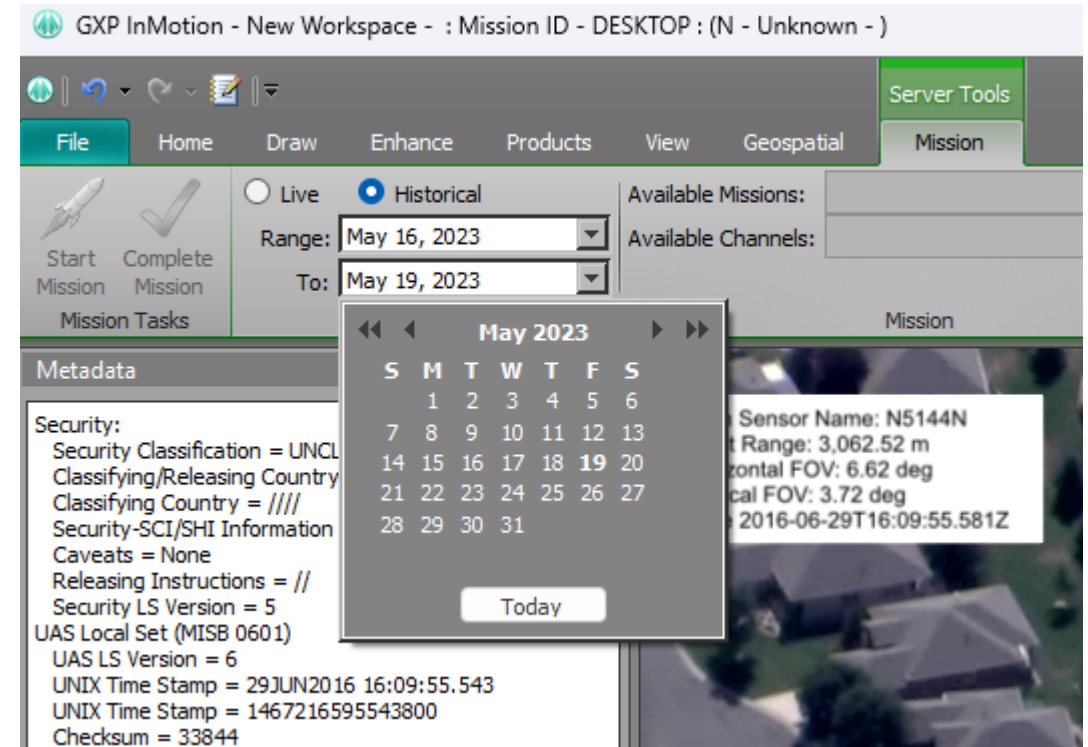

Imagery of MX-15 videos over Ft. Collins, CO; Courtesy of L-3 Communications, EO/IR Inc.

## GXP InMotion v4.5.1.0 – Enhanced video ‘time’ reporting

- Recently a customer reported that, *‘the time shown below the seek bar (at the right) is jumping backward and forward in time and it does not seem to show correct time’*.
- This behavior was normal as the time reported was based on the estimated time of available disk space, with elapsed time being from the start of a User Datagram Protocol (UDP) connection.
- With the v4.5.1.0 release, the seek bar now displays the elapsed time or duration time just like when displayed for live missions.

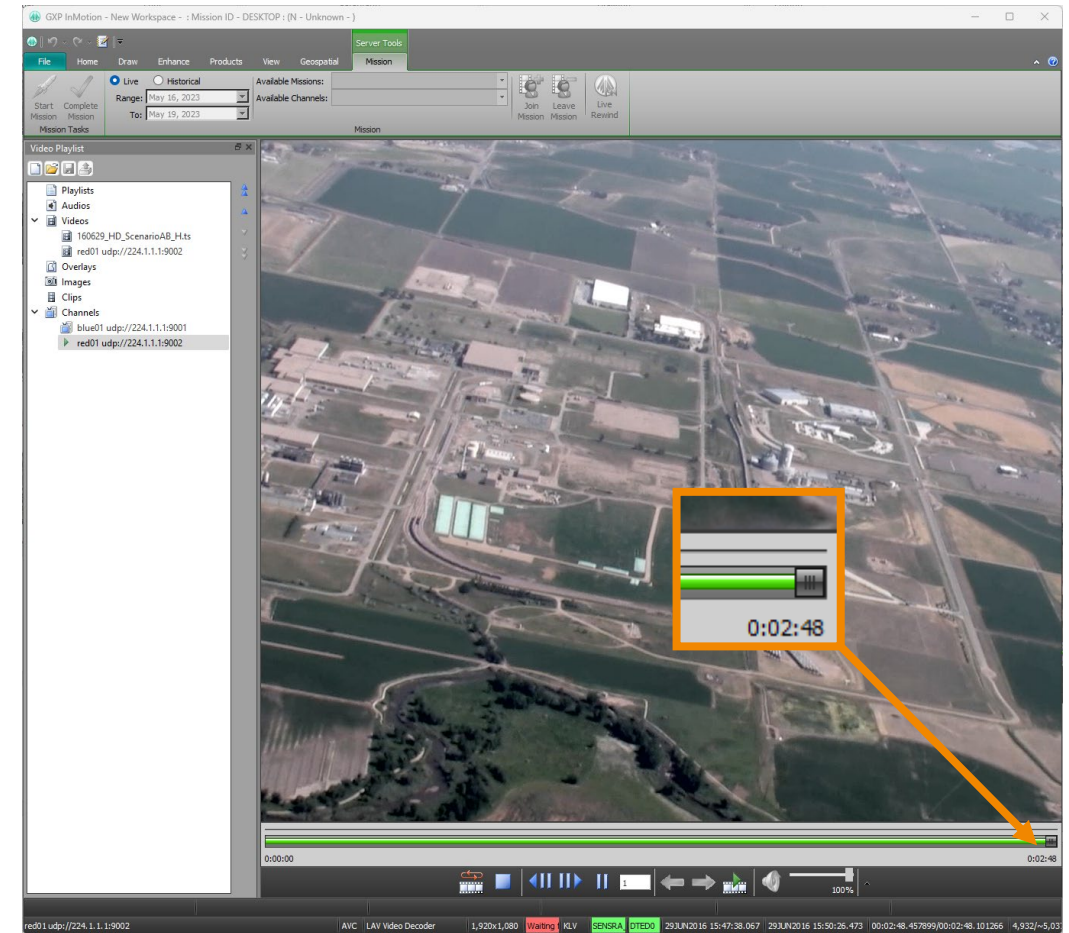

Imagery of MX-15 videos over Ft. Collins, CO; Courtesy of L-3 Communications, EO/IR Inc.

# GXP InMotion v4.5.1.0 – Enhanced Auto Label support

- Auto Labels have been supported for a long time in SOCKET GXP. In v4.5.0.7, GXP InMotion was updated to provide enhanced metadata support for Auto Labels.
- In v4.5.1.0, additional graphics file for Auto Labels include an update with how Auto Labels are displayed during video playback.

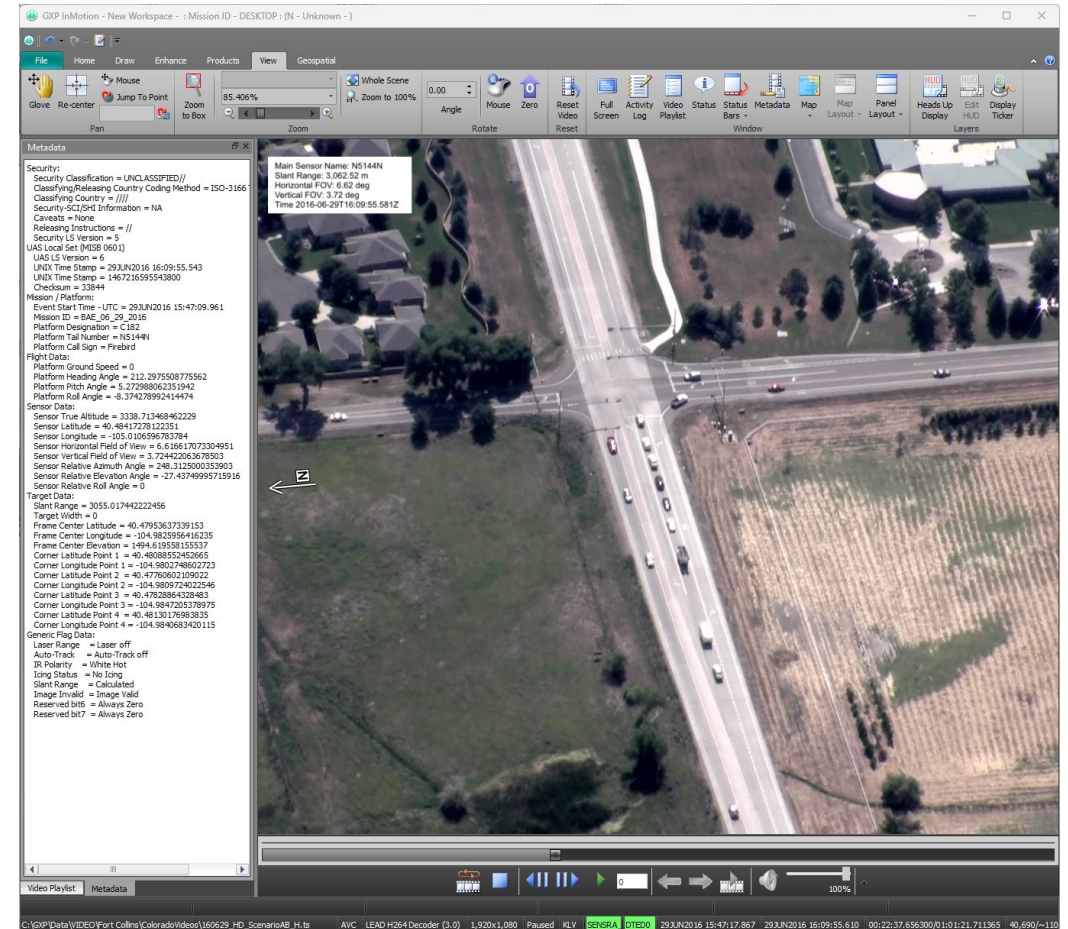

Imagery of MX-15 Imager over Ft. Collins, CO; Courtesy of L-3 Communications, EO/IR Inc.

# GXP InMotion v4.5.1.1 – Enhanced performance during playback

- Customer feedback highlighted that graphics and text that were displayed on video, the video playback would ‘hiccup’ occasionally.
- An investigation revealed that text rendering were the slowest of the two.
- The result was to make improvements and apply it to the rendering performance of specific text graphics layered on a video during playback:
  - Auto labels.
  - HUD.
  - Video Moving Target Indicators (VMTI).

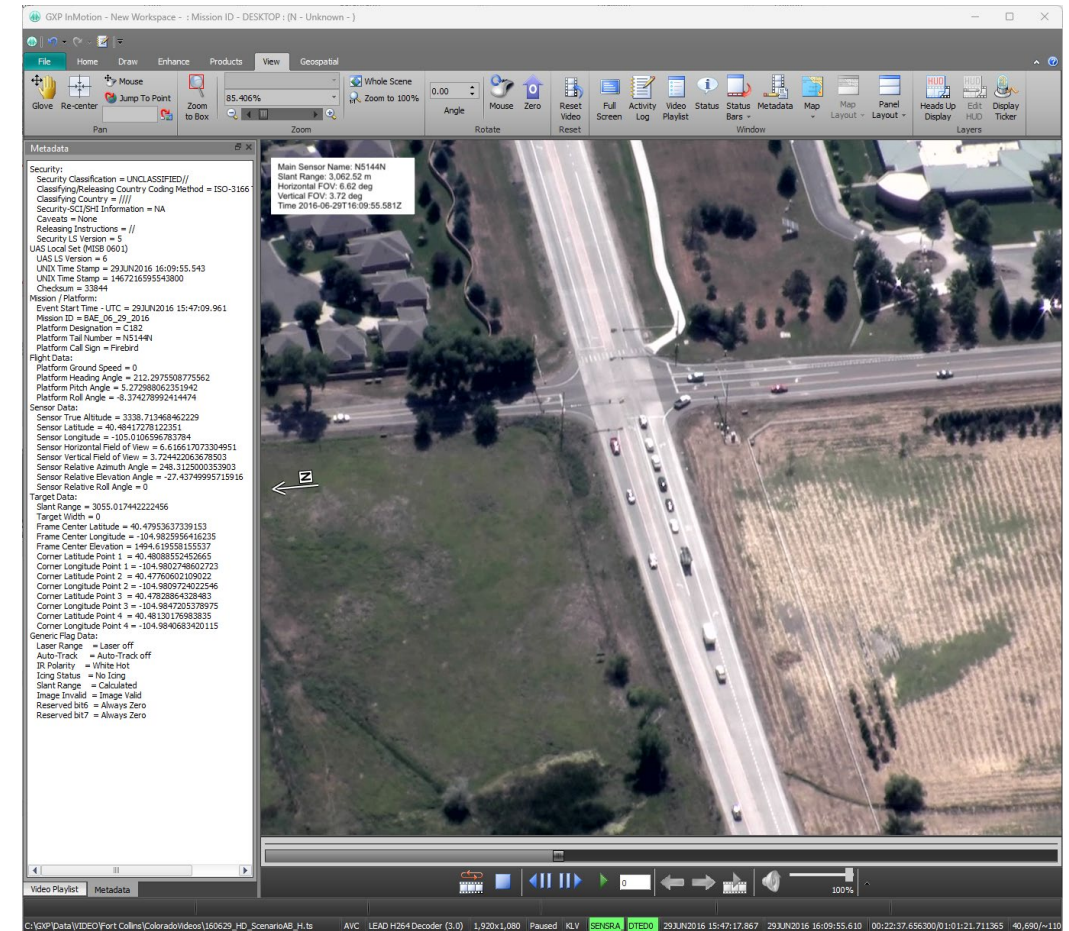

Imagery of MX-15 videos over Ft. Collins, CO; Courtesy of L-3 Communications, EO/IR Inc.

## GXP InMotion v4.5.1.2 – Support for Data Model (Version 2)

- GXP InMotion now connects to the recently updated Data Model Version 2 from the GXP Xplorer Platform enabling a fully ecosystem enabled data model experience for observation/activity management.
- A ‘data model’ is what organizations use for structuring observations.
- This solution was implemented to create an attribution scheme for activities that are congruent with GXP Xplorer Platform’s data model paradigm.
- The default attribution scheme was built and generated from customer feedback for typical attribution collection; however, the default scheme can be edited by administrators for tailored workflows.

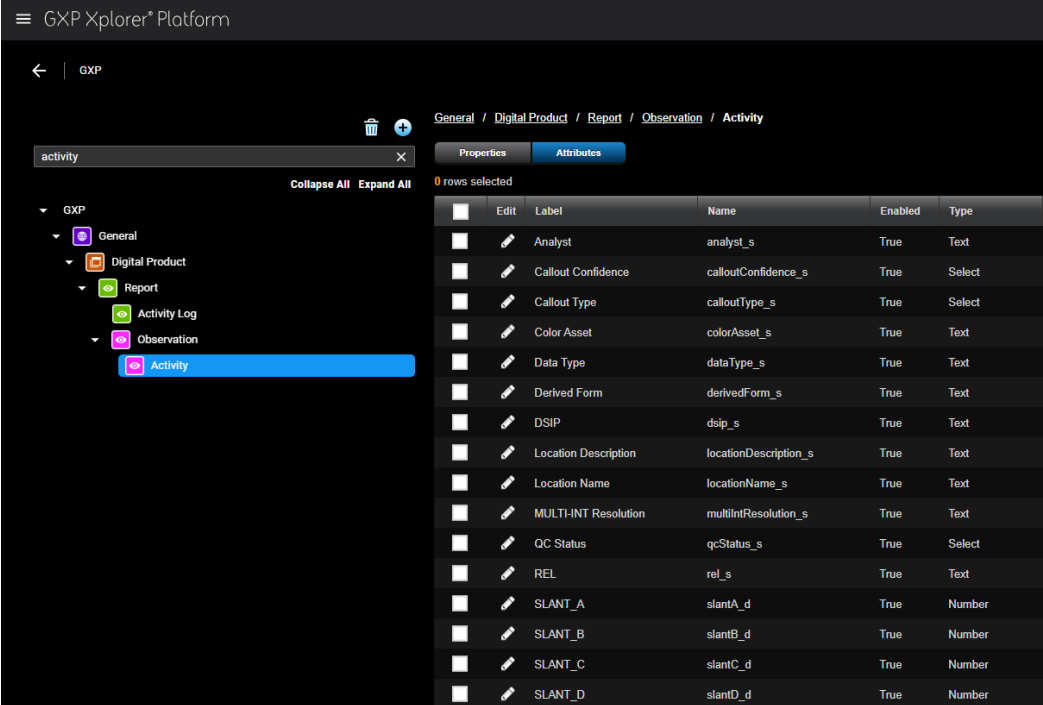

|                          | Edit | Label                | Name                  | Enabled | Type   |
|--------------------------|------|----------------------|-----------------------|---------|--------|
| <input type="checkbox"/> |      | Analyst              | analyst_s             | True    | Text   |
| <input type="checkbox"/> |      | Callout Confidence   | calloutConfidence_s   | True    | Select |
| <input type="checkbox"/> |      | Callout Type         | calloutType_s         | True    | Select |
| <input type="checkbox"/> |      | Color Asset          | colorAsset_s          | True    | Text   |
| <input type="checkbox"/> |      | Data Type            | dataType_s            | True    | Text   |
| <input type="checkbox"/> |      | Derived Form         | derivedForm_s         | True    | Text   |
| <input type="checkbox"/> |      | DSIP                 | dsip_s                | True    | Text   |
| <input type="checkbox"/> |      | Location Description | locationDescription_s | True    | Text   |
| <input type="checkbox"/> |      | Location Name        | locationName_s        | True    | Text   |
| <input type="checkbox"/> |      | MULT-INT Resolution  | multiIntResolution_s  | True    | Text   |
| <input type="checkbox"/> |      | QC Status            | qcStatus_s            | True    | Select |
| <input type="checkbox"/> |      | REL                  | rel_s                 | True    | Text   |
| <input type="checkbox"/> |      | SLANT_A              | slantA_d              | True    | Number |
| <input type="checkbox"/> |      | SLANT_B              | slantB_d              | True    | Number |
| <input type="checkbox"/> |      | SLANT_C              | slantC_d              | True    | Number |
| <input type="checkbox"/> |      | SLANT_D              | slantD_d              | True    | Number |



## GXP InMotion v4.5.1.2 – Support for Data Model (Version 2) ...2

- When users connect the desktop to an FMV mission from the GXP InMotion Server, the attribution scheme is sent to the desktop and the new attributes become available to all users of the mission. Users add the 'Available' attributes to the 'Selections' column so they are visible in the Activity Log.
- The attributes added to the Activity Log show up similar to what is seen here.

The screenshot displays the GXP InMotion software interface. A 'Column Settings' dialog box is open, showing a list of 'Available' attributes. An orange box highlights this list, and an orange arrow points from it to the 'Activity Log' table in the main interface. The 'Activity Log' table is also highlighted with an orange box and contains the following data:

| us | Objective Name | Analytical Comments | Video Time GMT           | Collection Time         | Center Coordinate              | QC Status | SLANT_A |
|----|----------------|---------------------|--------------------------|-------------------------|--------------------------------|-----------|---------|
|    | test           |                     | Jun 29, 2016, 3:51:51 PM | Feb 7, 2023, 5:57:33 PM | 40 27 15.8043N 104 50 44.4372W | Failed    |         |
|    |                |                     |                          |                         |                                | Nominated |         |
|    |                |                     |                          |                         |                                | Passed    |         |

Imagery of MX-15 videos over Ft. Collins, CO; Courtesy of L-3 Communications, EO/IR Inc.

## GXP InMotion v4.5.1.2 – ‘Fast’ and ‘Precise’ Track Generation

- The Fast and Precise Track Generation tools provide the user a way to review motion imagery data and identify pixel locations that are associated with track areas of interest.
- A specific track of interest is collected via either a ‘fast’ method (assisted), or a more ‘precise’ (manual) track extraction method.
- Users configure track sampling rates by frames or seconds and can be performed on an entire video file or the subset/region of the source.
- Works with both FMV or MIE4NITF data and the ability to edit individual features of a 4676 file were added to GXP InMotion.

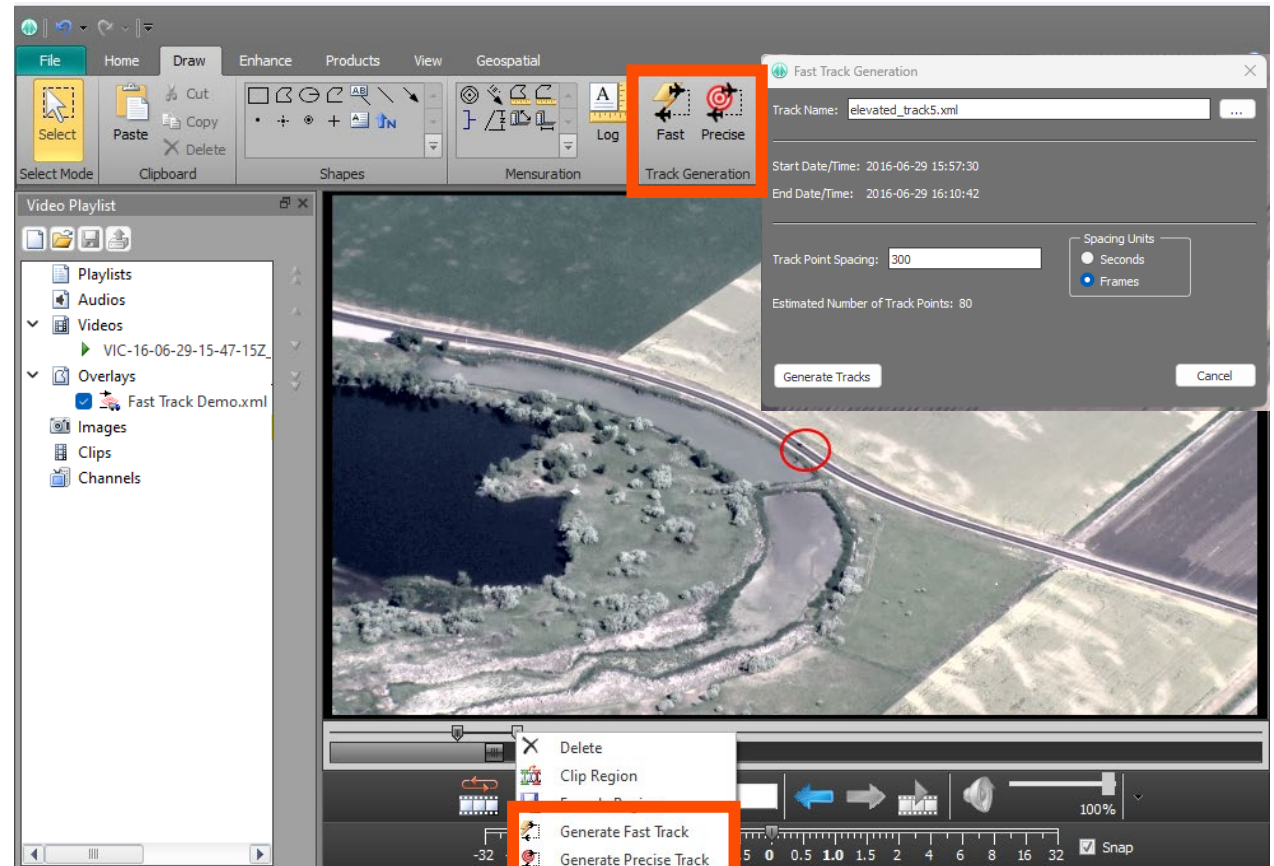

Imagery of MX-15 videos over Ft. Collins, CO; Courtesy of L-3 Communications, EO/IR Inc.

## GXP InMotion v4.5.1.2 – ‘Fast’ and ‘Precise’ Track Generation ...2

- The track generation creates a standards-based track (e.g. STANAG-4676B) and includes source references, such as source name, frame number/time, pixel location, ground location, instantaneous velocity, instantaneous heading, average speed for track, average heading for track, etc.
- Additionally, GXP InMotion now allows users to load and display corresponding track data over full motion video. Note:
  - FMV detections may be more sparse than the frames, so there may be gaps to deal with in the animation.
  - If there is no time overlap of 4676 data with the FMV loaded, then no animation will be supported.

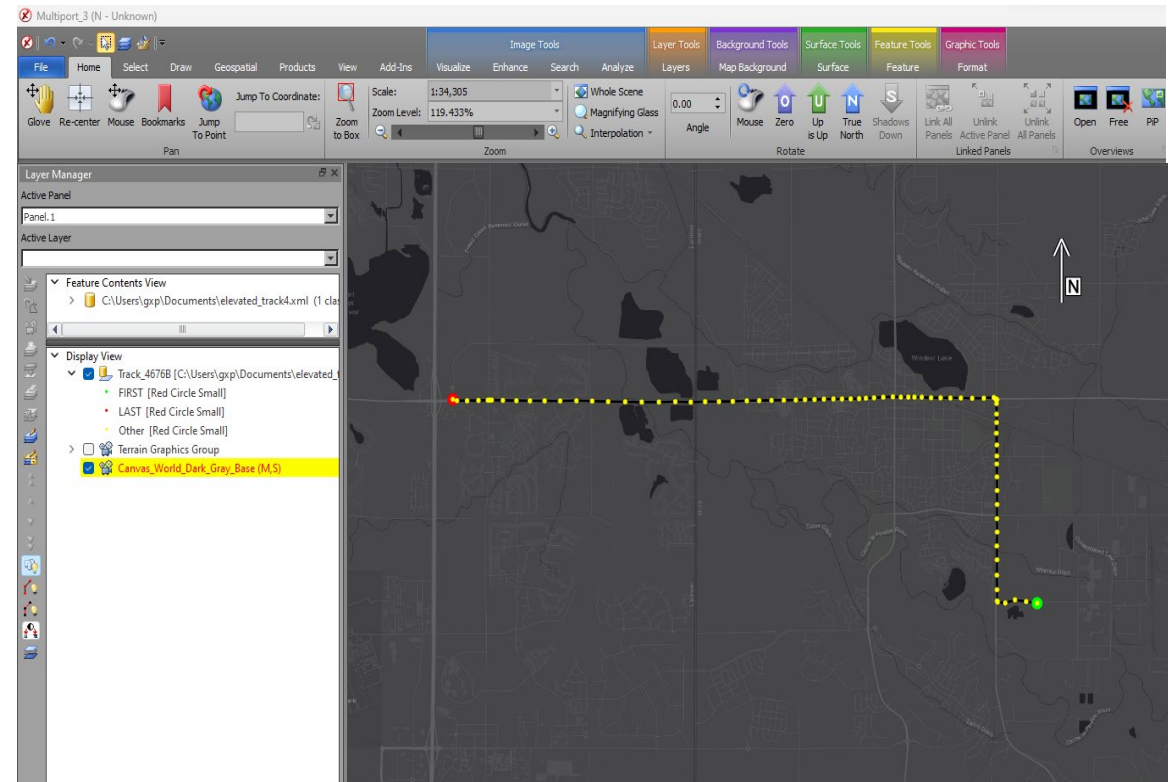

4676B derived from imagery of MX-15 videos over Ft. Collins, CO; Courtesy of L-3 Communications, EO/IR Inc.

# GXP InMotion v4.5.1.2 – 3D Multiport Support for Generated Tracks

- The new track generation tool creates enough information to enable a 3D Line-Of-Sight (LOS) visualization within SOCET GXP’s 3D Multiport.
- After a track is generated in GXP InMotion, the 3D Multiport will open, load the XML-based 4676B vector file and open the new Analysis Graph and Height Adjustment panel.
- The track is displayed along with vectors from the platform’s line of sight through the height column down to the ground.
- This interactive user interface aids in analysis of extracted flight tracks by plotting velocity vs. elevation, allowing users to adjust the time range for the track extracted.

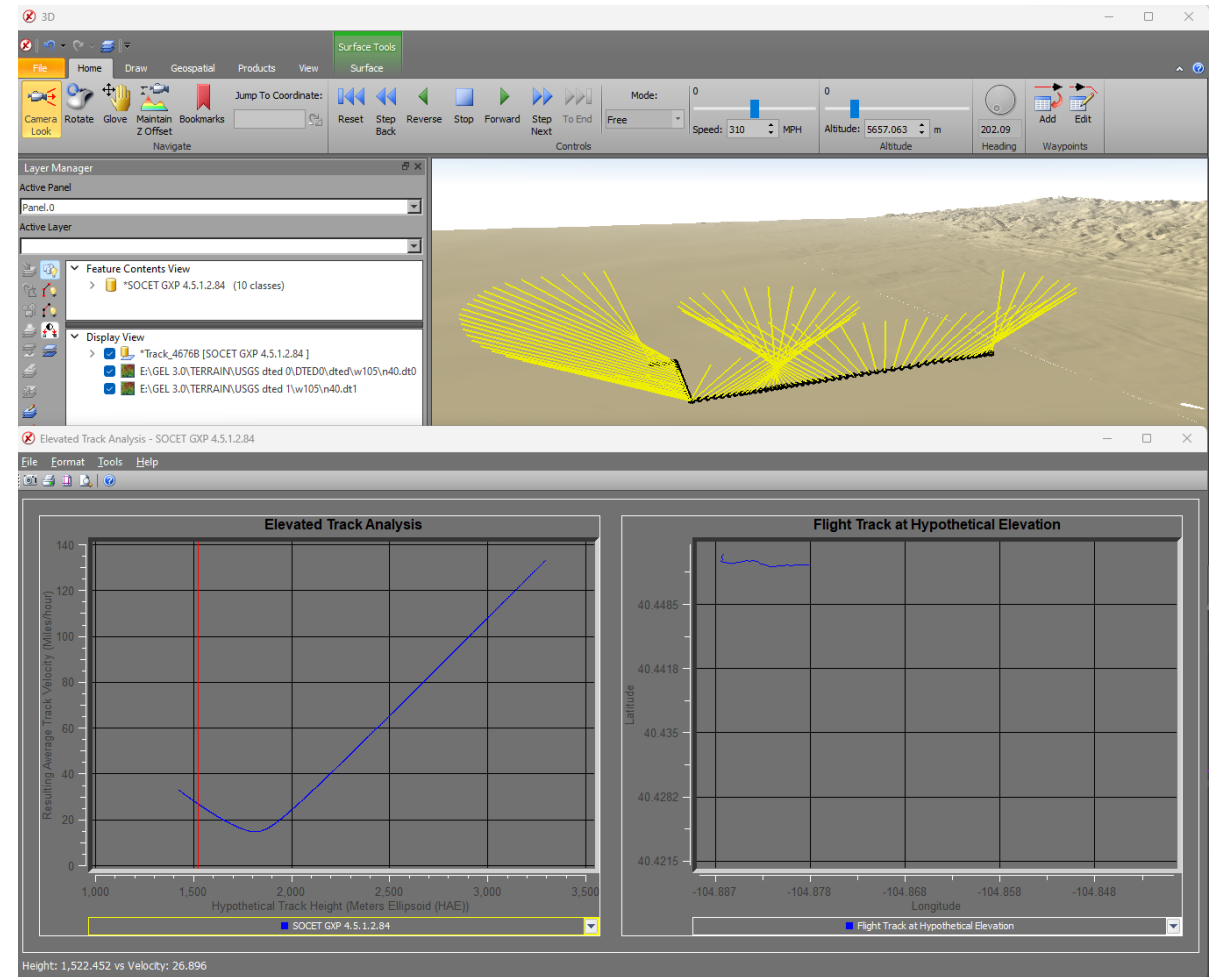

4676B derived from imagery of MX-15 videos over Ft. Collins, CO; Courtesy of L-3 Communications, EO/IR Inc.

## GXP InMotion v4.5.1.2 – ‘Properties’ support for vector files

- GXP InMotion has supported various vector files/feature data in the video window for many versions.
- As feedback surfaces from users, we have built up a picture that shows more and more use cases for vector data over motion imagery.
- For the first time, we have added the same ‘Properties’ UI seen in SOCET GXP for Feature layers into GXP InMotion.
- The following vector files are currently supported: STANAG-4676, KML/KMZ, Shapefiles, GeoJSON, and GMTI/4607.

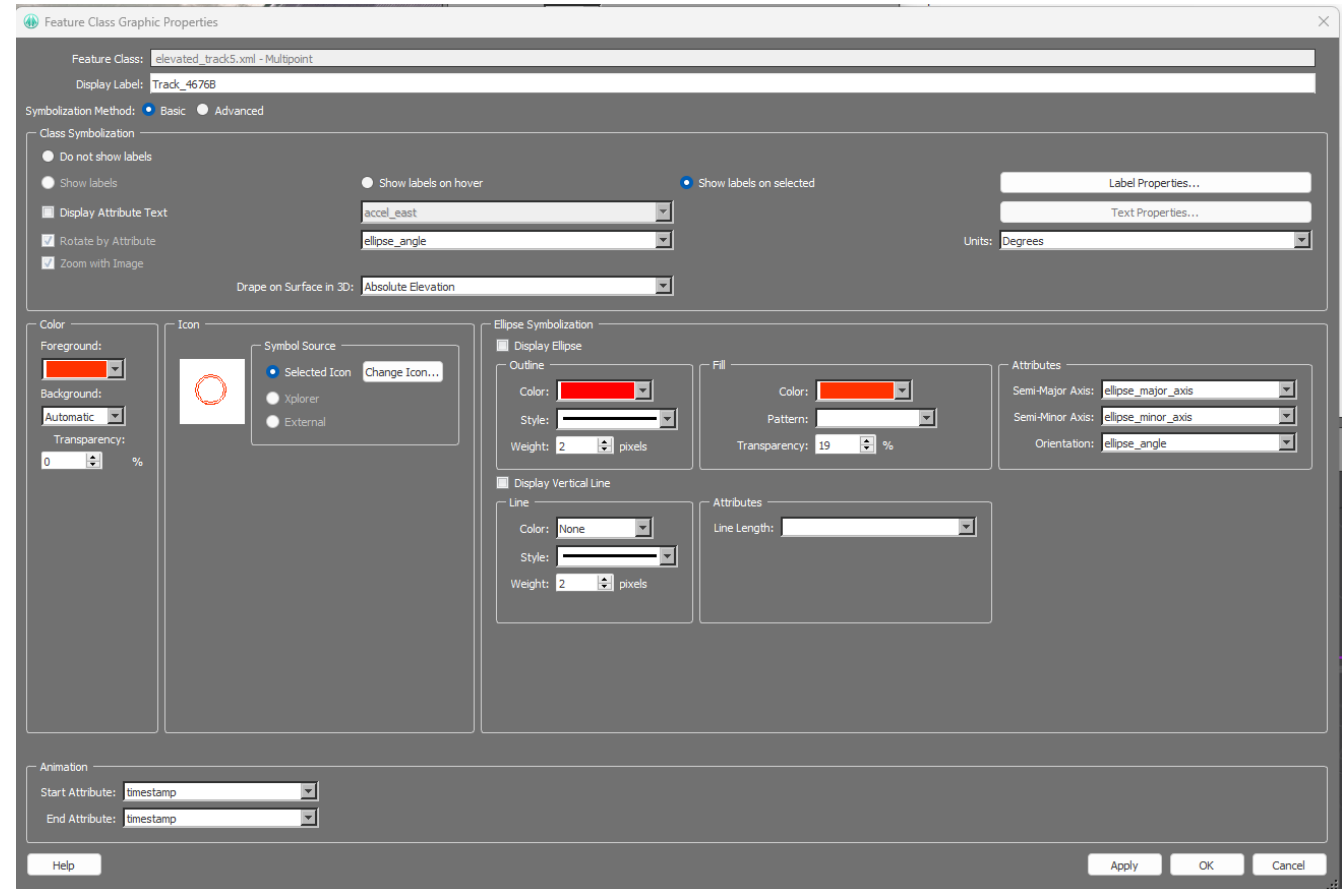

## GXP InMotion v4.5.1.2 – ‘Fallback’ Sensor Model for Vectors

- Display of both video and vector data navigates a complex mix of projections that for the most part are unnoticeable by users.
- Recently a use case emerged where displaying building footprints from a Shapefile resulted in a ‘cliff effect’ at the sensor-to-fallback boundary when the data has significant elevation.
- A Direct Linear Transformation ‘Fallback’ Sensor model was implemented to improve these scenarios.

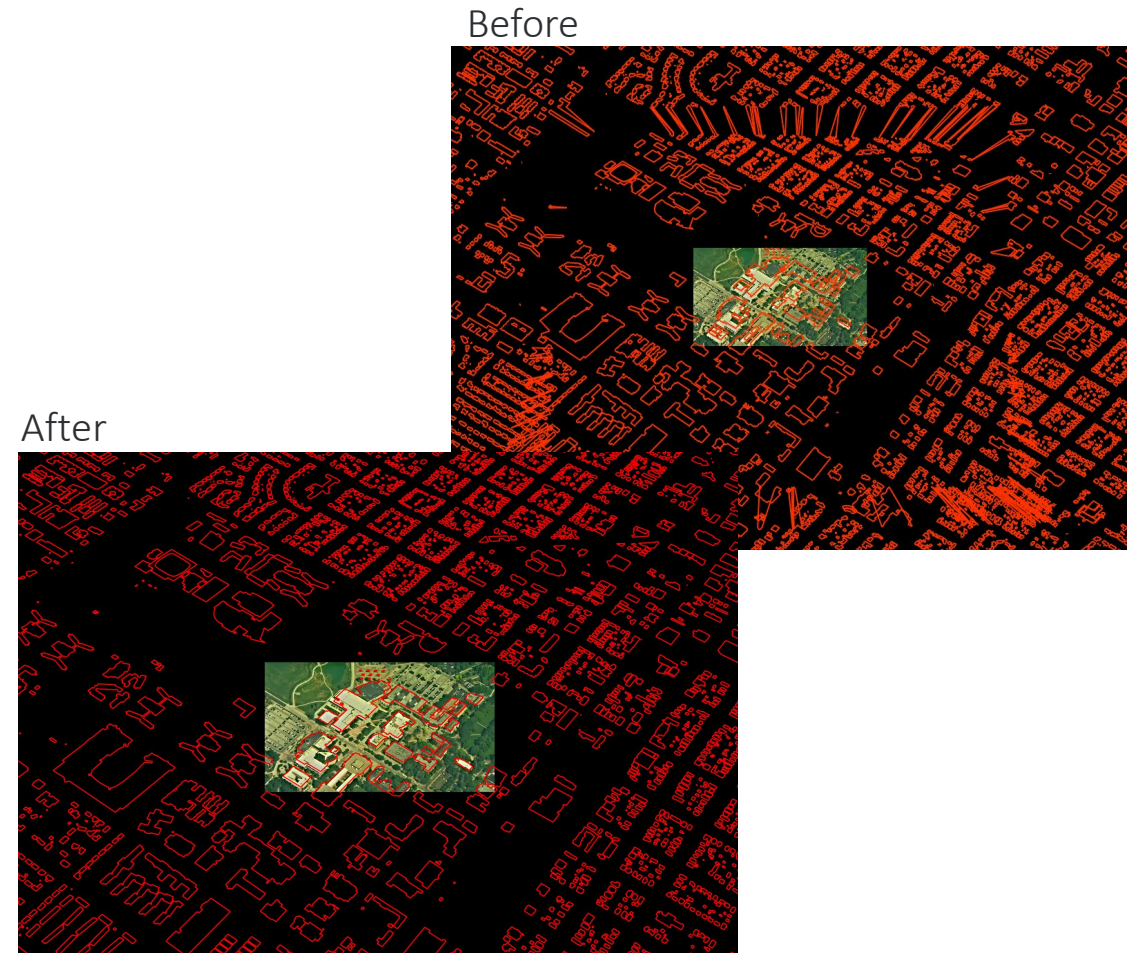

Imagery of MX-15 videos over Ft. Collins, CO; Courtesy of L-3 Communications, EO/IR Inc.

## Other significant enhancements

- Allow repair of 'orphaned' GMTI files
  - Originally found in v4.5.0.4.LEG.2, some GMTI/4607 data fails to load from a folder containing one mission. The SOCET GXP user receives an "Open Failed" message. Starting in v4.5.1.2, automatic detection of orphaned segments (dwells with no missions attached) will be conducted to allow repairs to these mission sets.
- When GXP InMotion Desktop joins a Mission, get most up-to-date mission information.
  - Currently, the GXP InMotion client periodically gets updates for missions (by default polling 25 seconds - and this is configurable). This means that the desktop client may not know about changes to mission in the last period of time and this could create a UDP-only load scenario for the desktop. This enhancement was to make sure that the desktop has the latest mission information at the time the mission will be connected. This should help prevent an edge case, where desktop user connects and gets a UDP-only view and creates activities with no video source data (see below).
- Warn GXP InMotion Desktop user when they are connecting to a UDP-only.
  - There are edge cases where a GXP InMotion desktop user may connect to a mission with a UDP-only feed. The user should be warned that they will be adding activities to a video source that will not have Mission capabilities for activity retention.
- Workspace Save/Open.
  - GXP InMotion 4.5.1.0 now allows users to save workspace. A workspace can save the current layout on the GXP InMotion Desktop window including the Video Layout and if the Map Panel/Map Window is shown. It should also have if the Dock Windows are shown. The data in the Video Playlist should also load and any data loaded in the Map Panel/Map Window should also load.

## Other significant enhancements... 2

- Update Access to GXP Xplorer/Tracking Analytics Software Suite (TASS) from Desktop and Use Secure / Authenticated Services.
  - The SOCET GXP/GXP InMotion Desktop will now be able to retrieve track data over Web Feature Service (WFS) through the platform and will no longer directly query TASS for WFS data. Additionally, the TASS WFS endpoint for the desktop now exposes https connectivity.
- Added support for:
  - Community Sensor Model (CSM) to GXP InMotion.
  - Amended FMV/KLV Metadata for registered products.
- API support:
  - Python wrapper for video Application Programming Interface (API).
  - Load a standard ID for every loaded video.
- Snapshot All Panels Into a Single Output Image file.



## Other significant enhancements... 3

- Use a fallback sensor model to deal with areas where SENS RB is not valid.
- Support Authentication to GXP InMotion Server configured for OpenID Connect (OIDC):
  - When the GXP Platform is configured to authenticate users with OIDC (e.g. GEOAxis), GXP InMotion Desktop is now able to authenticate and connect to the GXP InMotion Server. (Prerequisite: Platform 2.5.1.0 configured with OIDC authentication settings.)
- MISB 0601 Leap Seconds Support.
  - When the MISB 0601 leap seconds tag is provided in klv, we are applying it to all user-facing timestamp strings.
    - Status bar (Collection Start Time, Current Collection Time).
    - Metadata window.
    - HUD (Collection time).
    - NITF output files (image date/time).

# Thank you

**Evan Miller**

GXP Product Development

571-643-5070

[evan.miller2@baesystems.us](mailto:evan.miller2@baesystems.us)